

SPARE PARTS DRAWING

2016

1. PRUNING SAW
2. FOLDING SAW
3. POLE SAW
4. PRUNING SHEARS
5. FRUITS PRUNERS
6. LONG REACH PRUNERS
7. HEDGE SHEARS
8. LOPPING SHEARS
9. OTHER SHEARS



CAM-18PRO / CAM-24PRO

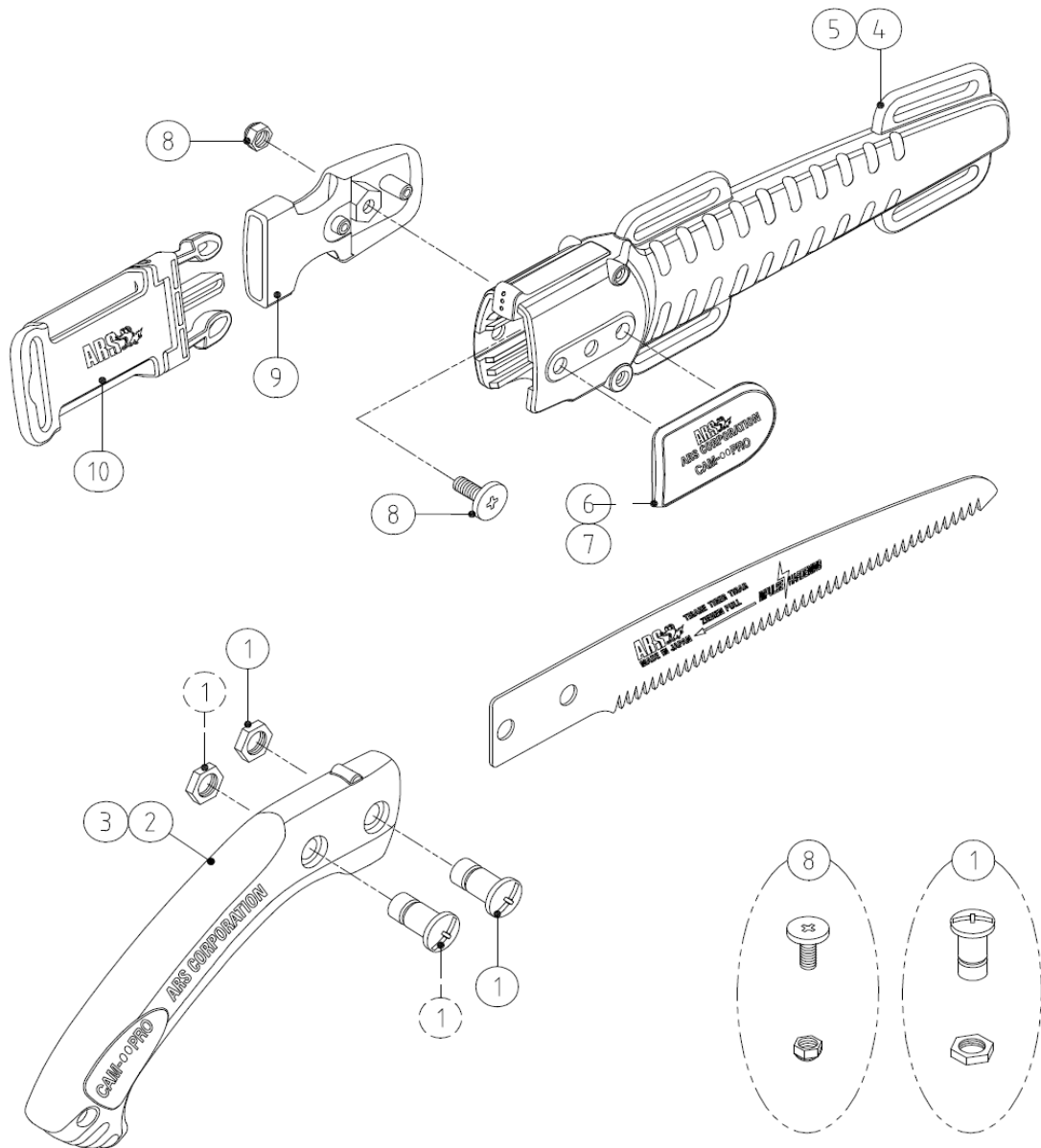

PARTS NO.	SPECIFICATION	PARTS NO.	SPECIFICATION
① SP-359	BOLT & NUT FOR CAM/CT/UV-PRO SERIES (1PC EACH)		
② SP-360	GRIP FOR CAM-18PRO		
③ SP-361	GRIP FOR CAM-24PRO		
④ SP-362	SHEATH ONLY, FOR CAM-18PRO (WITHOUT NAME PLATE OR BELT CLIP)		
⑤ SP-363	SHEATH ONLY, FOR CAM-24PRO (WITHOUT NAME PLATE OR BELT CLIP)		
⑥ SP-364	NAME PLATE FOR CAM-18PRO		
⑦ SP-365	NAME PLATE FOR CAM-24PRO		
⑧ SP-366	BOLT & NUT FOR THE BELT CLIP OF CAM/CT/UV-PRO SERIES		
⑨ SP-367	BELT CLIP FOR CAM/CT/UV-PRO SERIES		
⑩ SP-429	BELT FOR CAM/CT/UV-PRO SERIES		

CT-32PRO / UV-32PRO

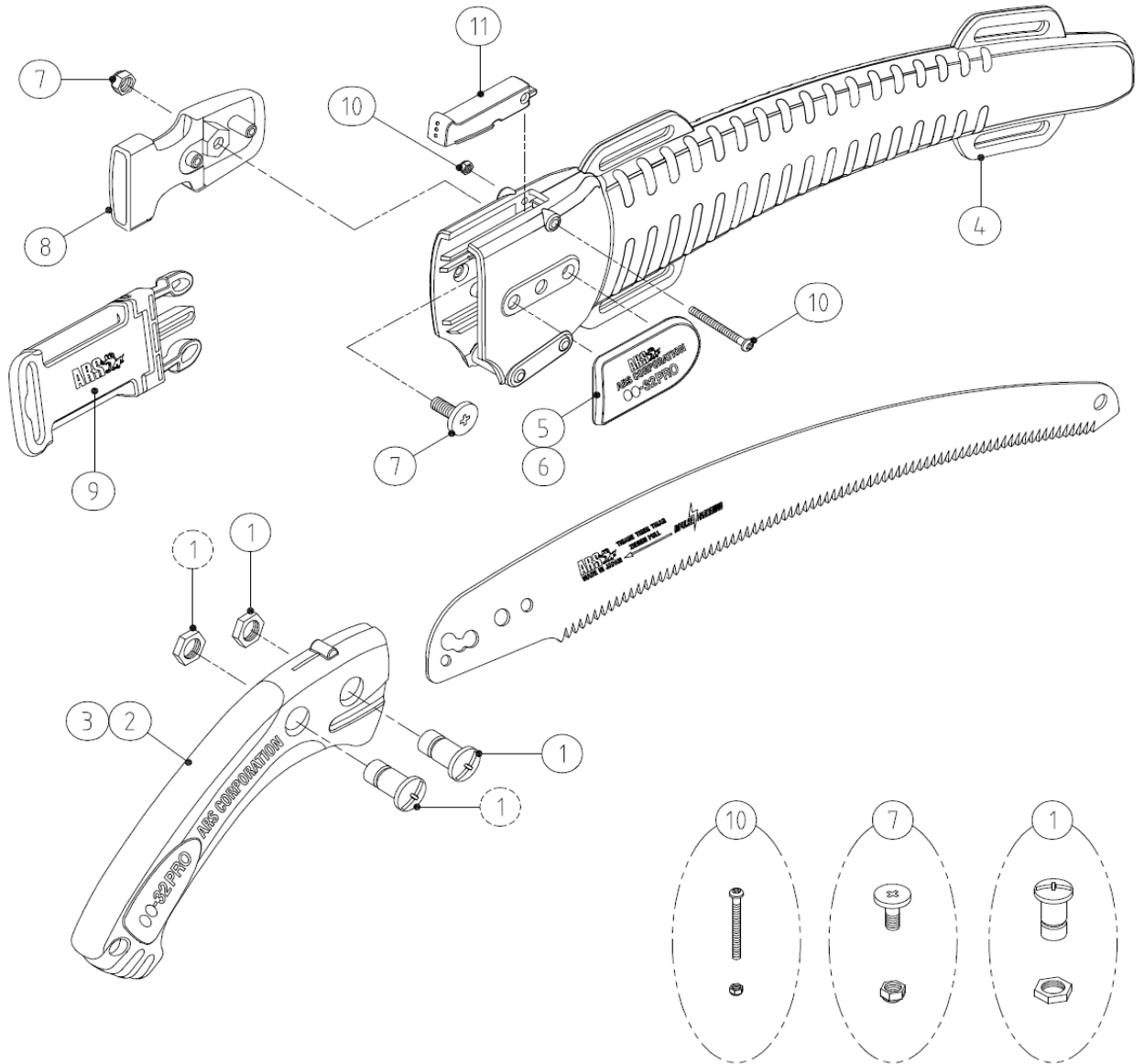

PARTS NO.	SPECIFICATION	PARTS NO.	SPECIFICATION
① SP-359	BOLT & NUT FOR CAM/CT/UV-PRO SERIES (1PC EACH)		
② SP-369	GRIP FOR CT-32PRO		
③ SP-374	GRIP FOR UV-32PRO		
④ SP-370	SHEATH FOR CT/UV-32PRO/-EXP (W/O STOPPER,NAME PLATE OR BELT CLIP)		
⑤ SP-371	NAME PLATE FOR CT-32PRO		
⑥ SP-375	NAME PLATE FOR UV-32PRO		
⑦ SP-366	BOLT & NUT FOR THE BELT CLIP OF CAM/CT/ UV-PRO SERIES		
⑧ SP-367	BELT CLIP FOR CAM/CT/UV-PRO SERIES		
⑨ SP-429	BELT FOR CAM/CT/UV-PRO SERIES		
⑩ SP-373	BOLT & NUT FOR STOPPER OF CT/UV-32PRO/ -EXP/37PRO/42PRO		
⑪ SP-372	STOPPER FOR CT/UV-32PRO/37PRO/42PRO		

CT-37PRO / UV-37PRO

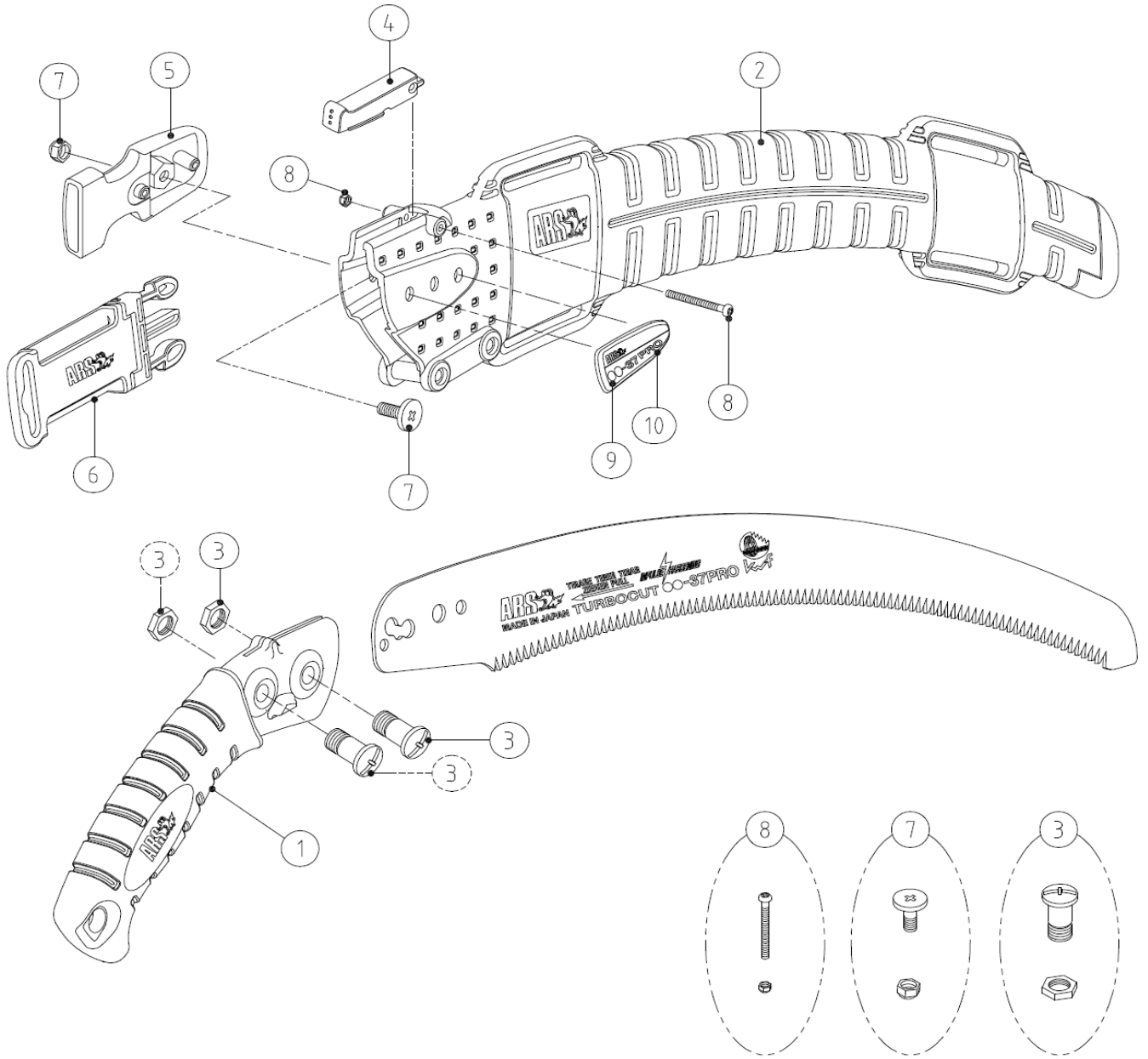

PARTS NO.	SPECIFICATION	PARTS NO.	SPECIFICATION
①	SP-427 GRIP FOR CT/UV-37PRO/42PRO		
②	SP-428 SHEATH FOR CT/UV-37PRO/42PRO (W/O STOPPER,NAME PLATE OR BELT CLIP)		
③	SP-359 BOLT & NUT FOR CAM/CT/UV-PRO SERIES (1PC EACH)		
④	SP-372 STOPPER FOR CT/UV-32PRO/37PRO/42PRO		
⑤	SP-367 BELT CLIP FOR CAM/CT/UV-PRO SERIES		
⑥	SP-429 BELT FOR CAM/CT/UV-PRO SERIES		
⑦	SP-366 BOLT & NUT FOR THE BELT CLIP OF CAM/CT/UV-PRO SERIES		
⑧	SP-373 BOLT & NUT FOR STOPPER OF CT/UV-32PRO/ -EXP/37PRO/42PRO		
⑨	SP-430 NAME PLATE FOR CT-37PRO		
⑩	SP-431 NAME PLATE FOR UV-37PRO		

CT-42PRO / UV-42PRO

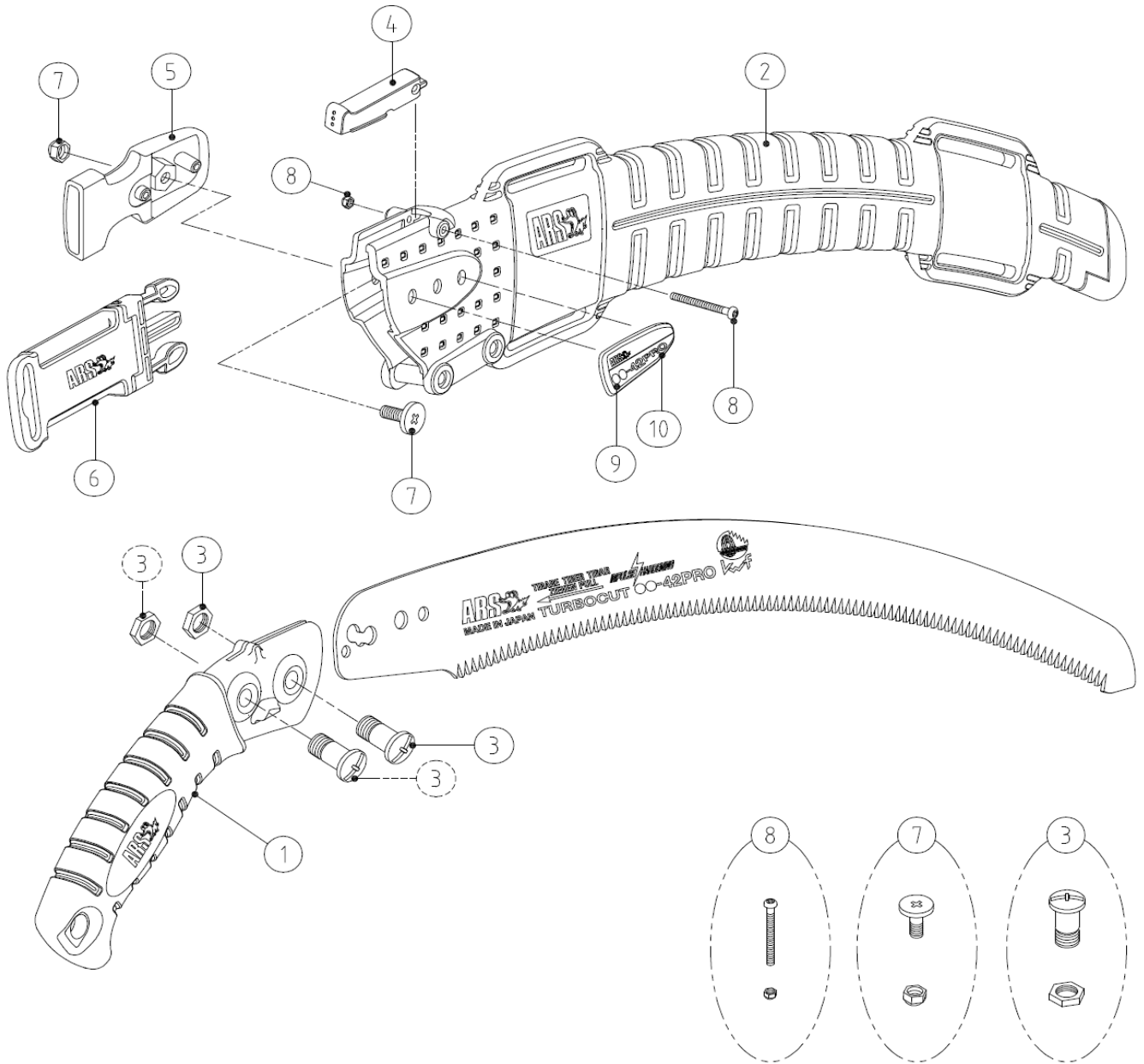

PARTS NO.	SPECIFICATION	PARTS NO.	SPECIFICATION
①	SP-427 GRIP FOR CT/UV-37PRO/42PRO		
②	SP-428 SHEATH FOR CT/UV-37PRO/42PRO (W/O STOPPER, NAME PLATE OR BELT CLIP)		
③	SP-359 BOLT & NUT FOR CAM/CT/UV-PRO SERIES (1PC EACH)		
④	SP-372 STOPPER FOR CT/UV-32PRO/37PRO/42PRO		
⑤	SP-367 BELT CLIP FOR CAM/CT/UV-PRO SERIES		
⑥	SP-429 BELT FOR CAM/CT/UV-PRO SERIES		
⑦	SP-366 BOLT & NUT FOR THE BELT CLIP OF CAM/CT/UV-PRO SERIES		
⑧	SP-373 BOLT & NUT FOR STOPPER OF CT/UV-32PRO/ -EXP/37PRO/42PRO		
⑨	SP-443 NAME PLATE FOR CT-42PRO		
⑩	SP-444 NAME PLATE FOR UV-42PRO		

PM-21 / PM-21L / PM-24 / PM-24L

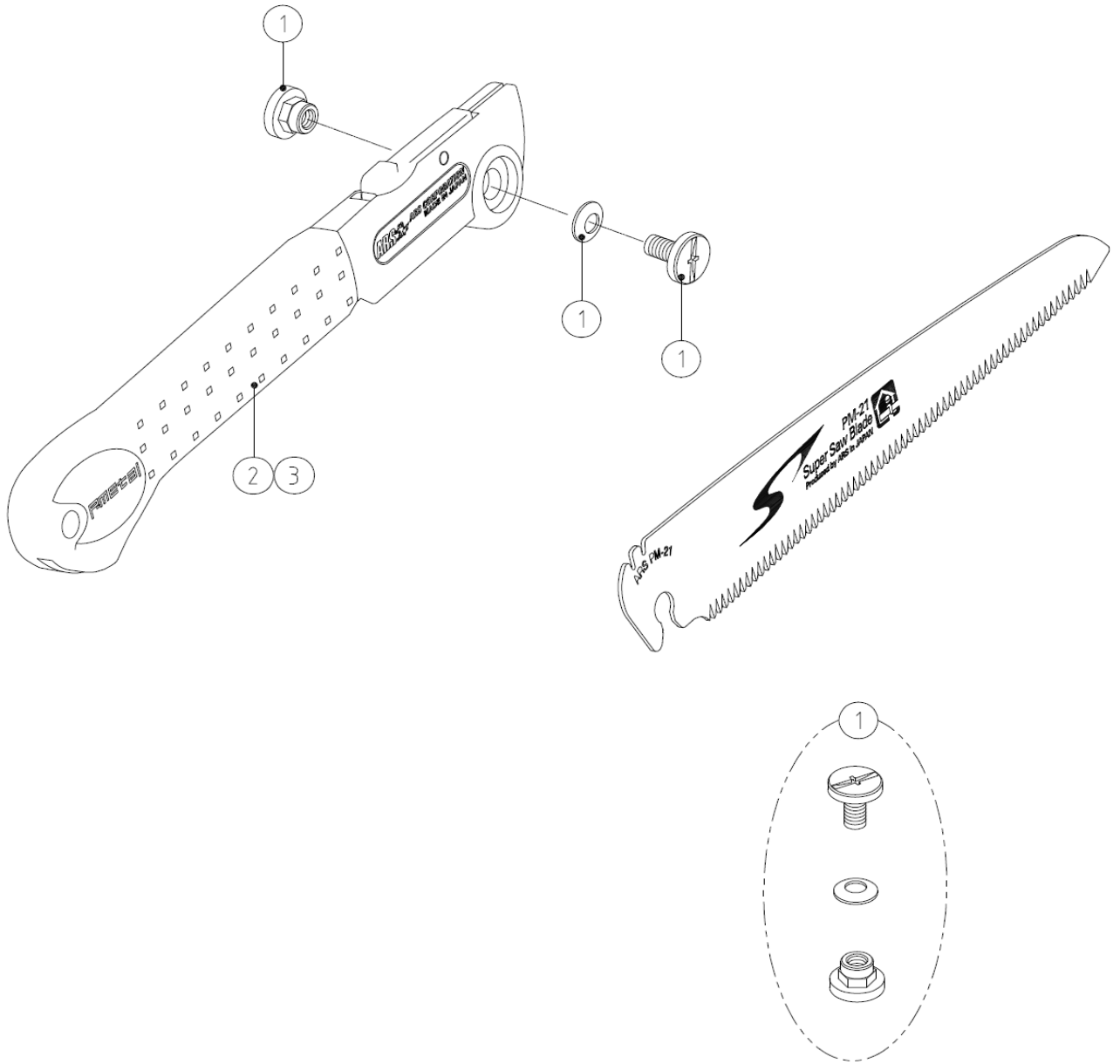

PARTS NO.	SPECIFICATION	PARTS NO.	SPECIFICATION
① SP-324	BOLT, NUT & WASHER FOR PM-21/21L/24/24L		
② SP-325	GRIP FOR PM-21/21L		
③ SP-326	GRIP FOR PM-24/24L		

EXP-3.3 / EXP-4.5 / EXP-5.5

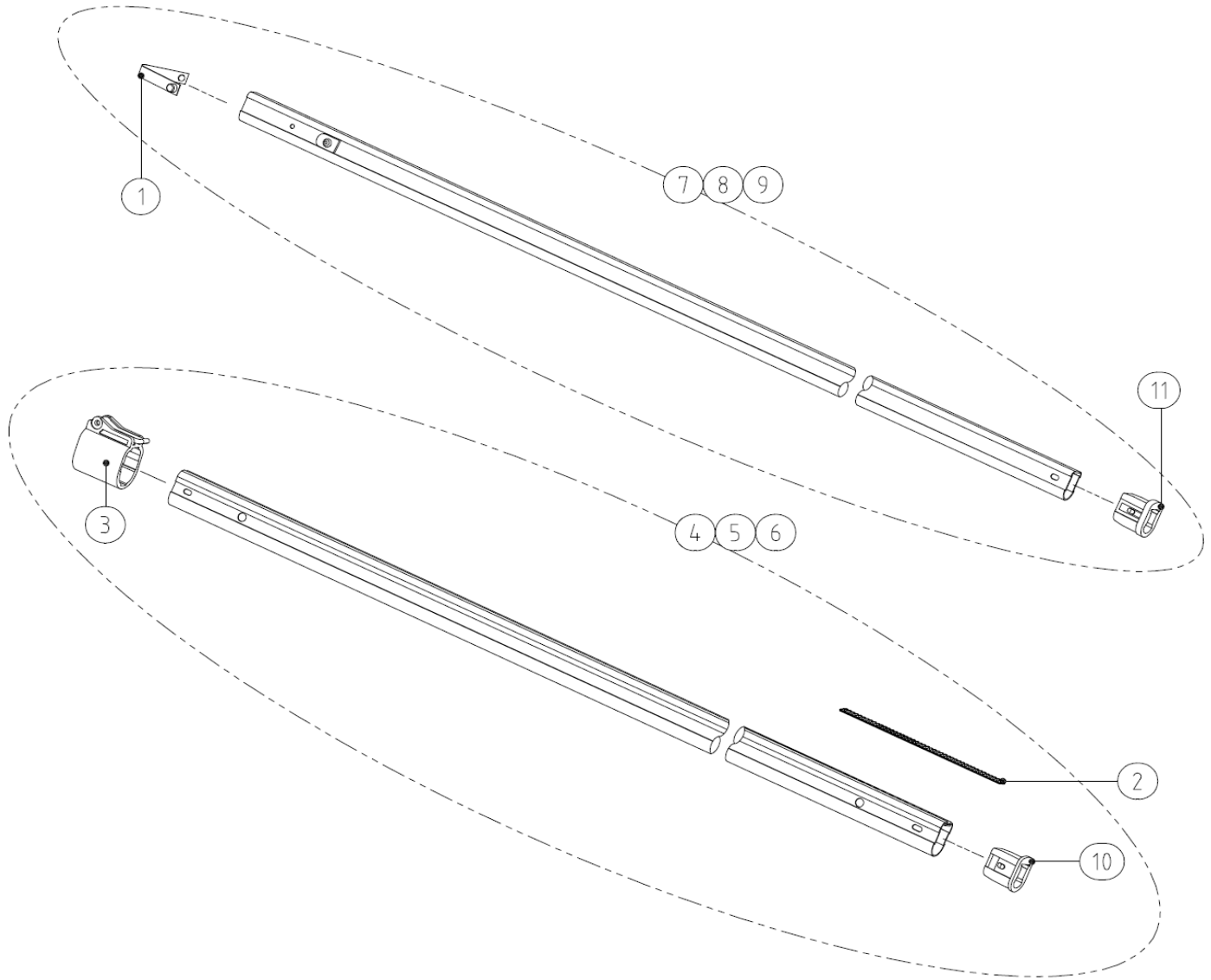

PARTS NO.	SPECIFICATION	PARTS NO.	SPECIFICATION
① SP-110	PRESS BUTTON W/SPRING, FOR EXP SERIES	⑩ SP-119	ENDCAP FOR B PIPE OF EXP SERIES
② SP-111	PLASTIC GUIDE FOR EXP-4.5/EXP-5.5 (1 PC.)	⑪ SP-120	ENDCAP FOR C PIPE OF EXP SERIES
SP-111-A	PLASTIC GUIDE SET FOR EXP-4.5 (6 PCS.)		
SP-111-B	PLASTIC GUIDE SET FOR EXP-5.5 (8 PCS.)		
SP-111-C	PLASTIC GUIDE SET FOR EXP-3.3 (5 PCS.)		
③ SP-113-A	STOPPER SET FOR MIDDLE PIPE (B PIPE) OF EXP-4.5		
SP-113-B	STOPPER SET FOR MIDDLE PIPE (B PIPE) OF EXP-5.5		
SP-113-D	STOPPER SET FOR MIDDLE PIPE (B PIPE) OF EXP-3.3		
④ SP-328	B PIPE FOR EXP-3.3		
⑤ SP-116	MIDDLE PIPE (B PIPE) OF EXP-4.5		
⑥ SP-103	B PIPE FOR EXP-5.5		
⑦ SP-329	C PIPE FOR EXP-2.3/3.3		
⑧ SP-117	UPPER PIPE (C PIPE) OF EXP-4.5		
⑨ SP-104	C PIPE FOR EXP-5.5		

EXW-1.8 / EXW-2.7

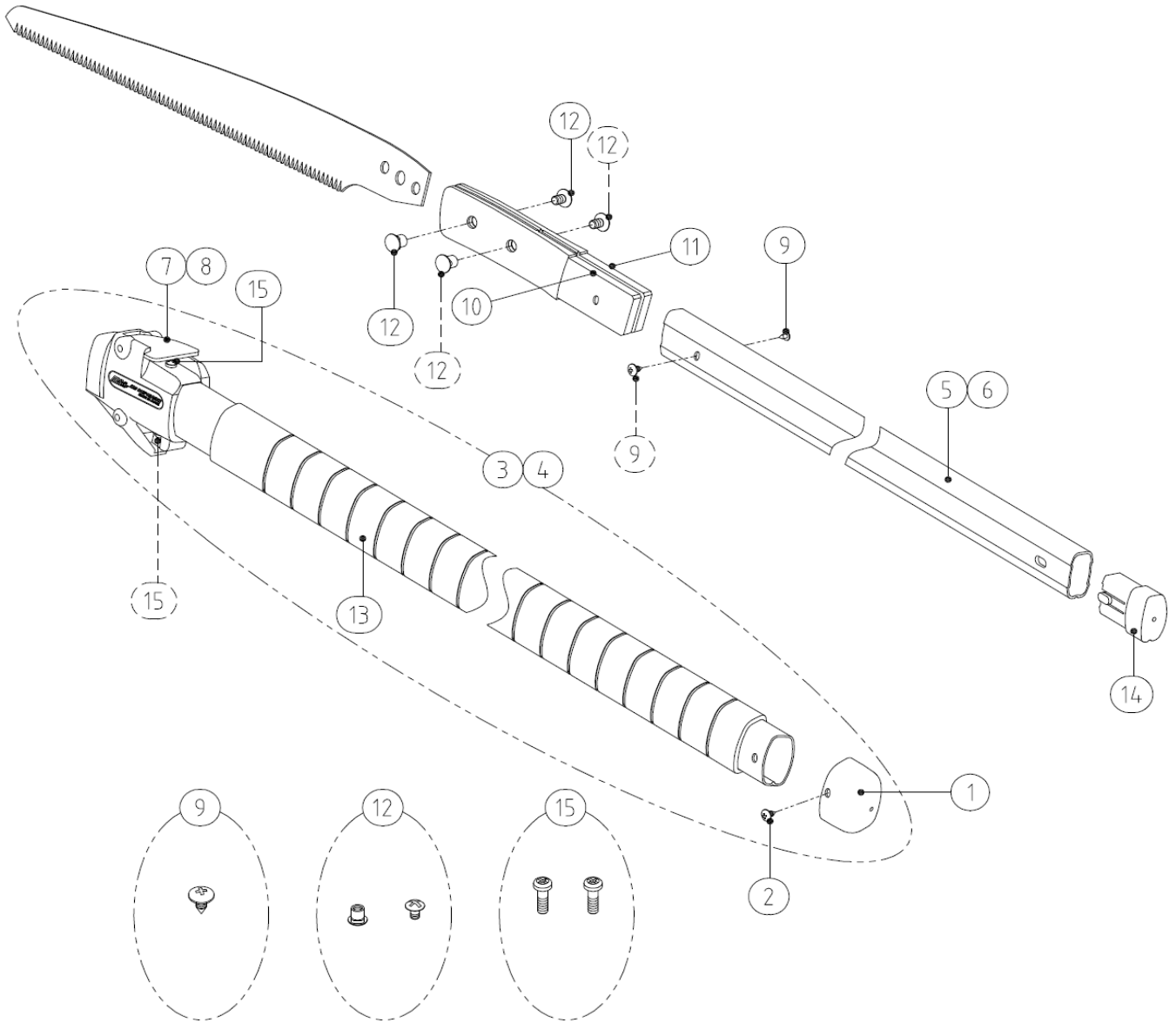

PARTS NO.	SPECIFICATION	PARTS NO.	SPECIFICATION
① SP-300	ENDCAP FOR THE BOTTOM PIPE FOR EXW-1.8/2.7	⑫ SP-308	BLADE HOLDING BOLT & NUT FOR EXW-1.8/2.7 (1PC EACH)
② SP-301	ENDCAP HOLDING SCREW FOR EXW-1.8/2.7 (1PC)	⑬ SP-309	PLASTIC GRIP ONLY FOR THE BOTTOM PIPE FOR EXW-1.8/2.7(1/2 PC.)
③ SP-302	BOTTOM GRIP SET FOR EXW-1.8 (ICL.GRIP AND JOINT CASE)	⑭ SP-310	ENDCAP FOR INNER PIPE FOR EXW-1.8/2.7
④ SP-311	BOTTOM GRIP SET EXW-2.7 (ICL.GRIP AND JOINT CASE)	⑮ SP-333	SCREW OF JOINT CASE FOR EXW-1.8/2.7 (2PCS)
⑤ SP-303	INNER PIPE FOR EXW-1.8 (W/O BLADE HOLDER)		
⑥ SP-312	INNER PIPE FOR EXW-2.7 (W/O BLADE HOLDER)		
⑦ SP-304-A	JOINT CASE FOR EXW-1.8 WITH SCREW		
⑧ SP-304-B	JOINT CASE FOR EXW-2.7 WITH SCREW		
⑨ SP-305	HOLDER FIXING BOLT & NUT FOR EXW-1.8/2.7 (1PC)		
⑩ SP-307	BLADE HOLDER(LEFT) FOR EXW-1.8/2.7		
⑪ SP-306	BLADE HOLDER(RIGHT) FOR EXW-1.8/2.7		

CB-8 / CB-9

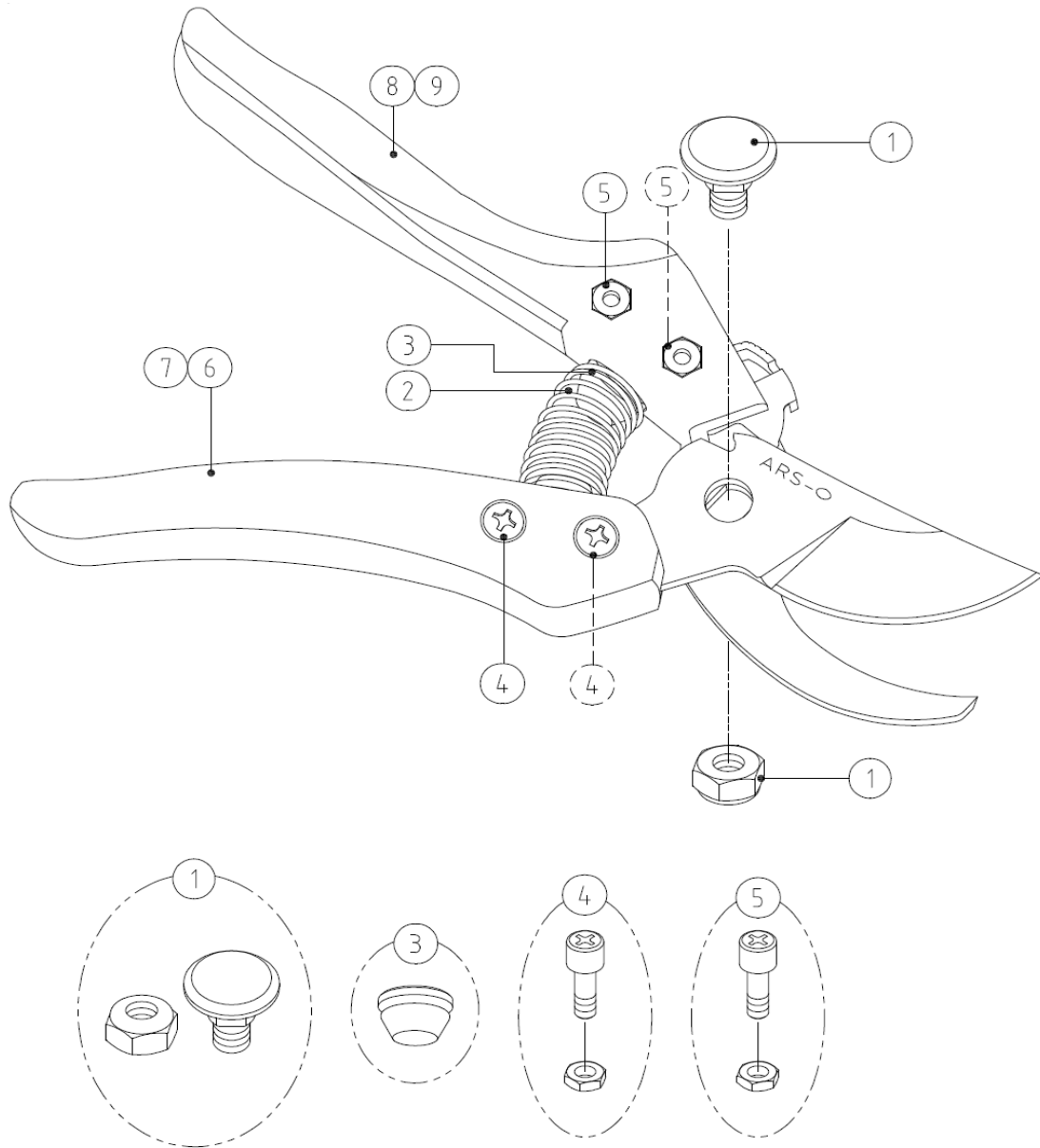

PARTS NO.	SPECIFICATION	PARTS NO.	SPECIFICATION
①	SP-217 CENTER BOLT & NUT FOR CB-8/CB-9/ CBR-8/CBR-9		
②	SP-218 SPRING FOR CB-8/CB-9/CBR-8/CBR-9		
③	SP-432 RUBBER CUSHION FOR VS-7R/7Z AND CB-8/9 (RED, 1 PC)		
④	SP-220 BOLT & NUT FOR THE CUTTING BLADE GRIP FOR CB-8/9 (1 PC EACH)		
⑤	SP-221 BOLT & NUT FOR THE COUNTER BLADE GRIP FOR CB-8/9 (1 PC EACH)		
⑥	SP-313 CUTTING BLADE GRIP FOR CB-8		
⑦	SP-315 CUTTING BLADE GRIP FOR CB-9		
⑧	SP-314 COUNTER BLADE GRIP FOR CB/CBR-8		
⑨	SP-316 COUNTER BLADE GRIP FOR CB/CBR-9		

VS-7R / VS-8R / VS-9R

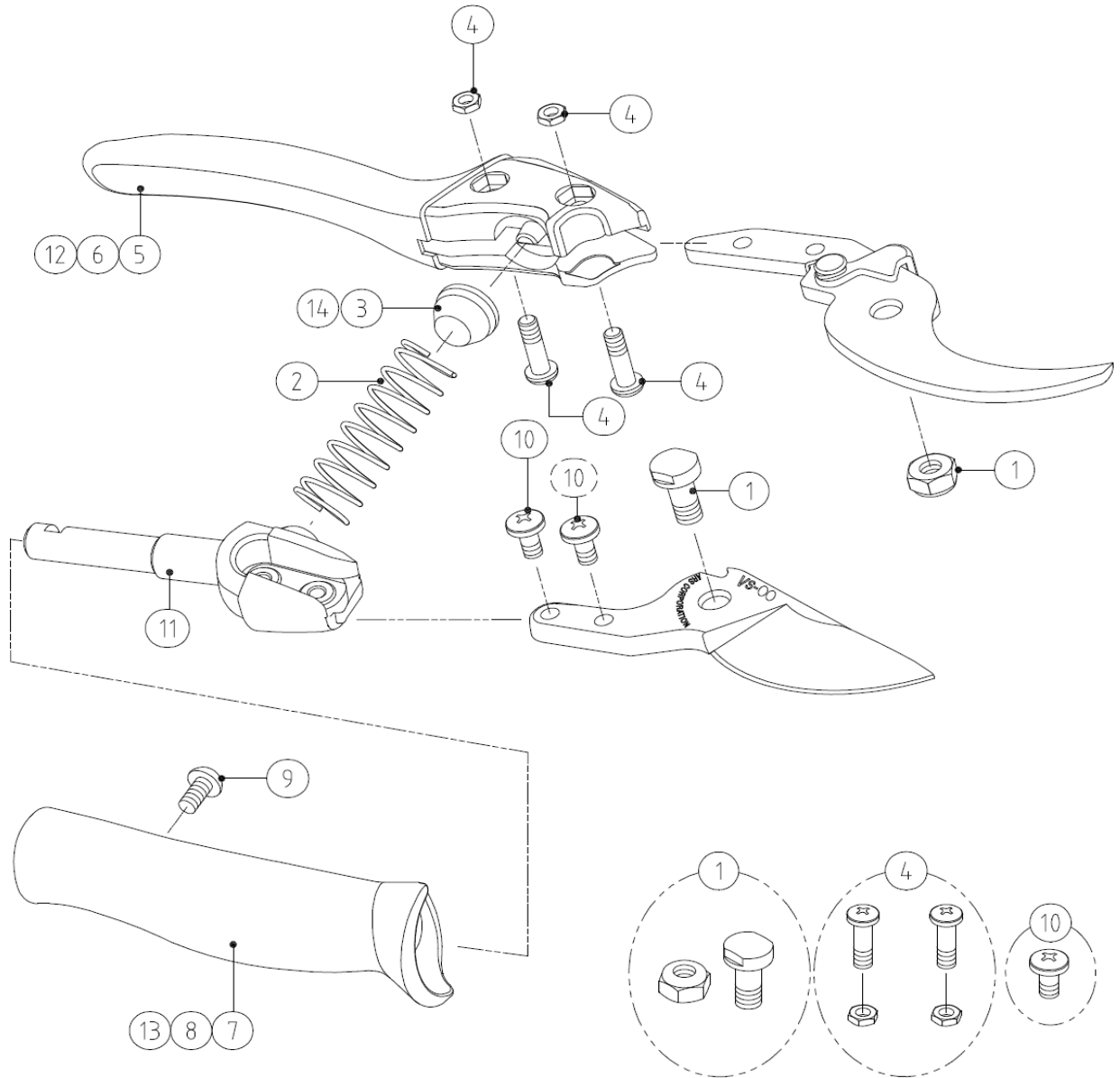

PARTS NO.	SPECIFICATION	PARTS NO.	SPECIFICATION
① SP-60	BOLT & NUT FOR V & VS SERIES	⑫ SP-415	COUNTER BLADE GRIP FOR VS-7Z/VS-7R
② SP-61	SPRING FOR V-7Z/8Z/9Z, 130DX, 140DX, 140L-DX & VS SERIES	⑬ SP-416	ROTARY GRIP FOR VS-7R
③ SP-151	RUBBER CUSHION FOR V SERIES & VS-8/9 SERIES (1PC)	⑭ SP-432	RUBBER CUSHION FOR VS-7R/7Z AND CB-8/9 (RED,1PC)
④ SP-323	HANDLE SCREW & NUT FOR V & VS SERIES (2PCS EACH)		
⑤ SP-396	COUNTER BLADE GRIP FOR VS-8Z/VS-8R		
⑥ SP-402	COUNTER BLADE GRIP FOR VS-9R/VS-9Z		
⑦ SP-397	ROTARY GRIP FOR VS-8R		
⑧ SP-403	ROTARY GRIP FOR VS-9R		
⑨ SP-395	BOLT FOR ROLL GRIP FOR VS-7R/8R/9R		
⑩ SP-394	BLADE HOLDING BOLT FOR THE CUTTING BLADE OF VS-7R/8R/9R (1PC)		
⑪ SP-398	AXLE (SHAFT) FOR ROTARY GRIP FOR VS-7R/8R/9R		

VS-7Z / VS-8Z / VS-9Z

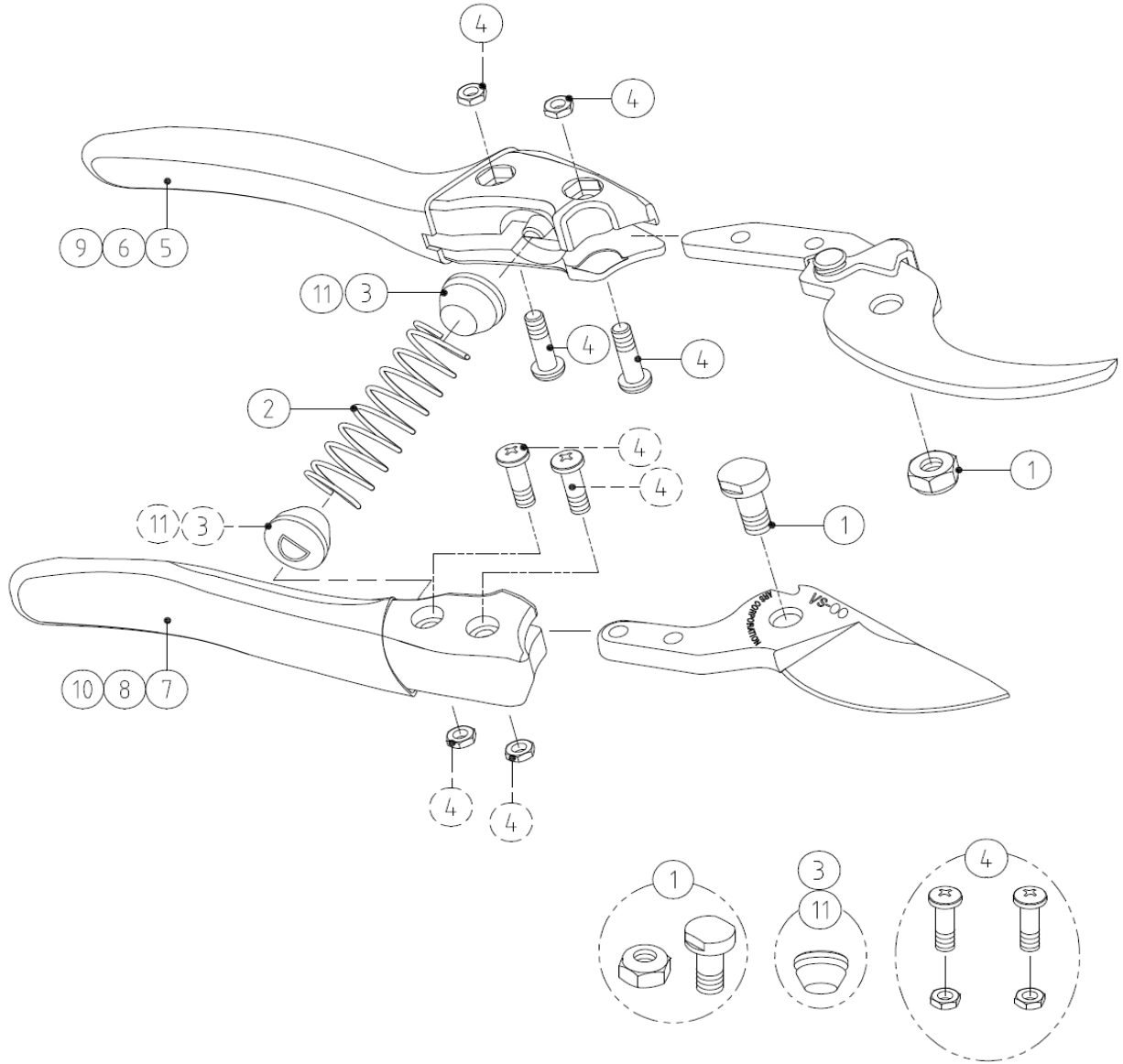

PARTS NO.	SPECIFICATION	PARTS NO.	SPECIFICATION
① SP-60	BOLT & NUT FOR V & VS SERIES		
② SP-61	SPRING FOR V-7Z/8Z/9Z, 130DX, 140DX, 140L-DX & VS SERIES		
③ SP-151	RUBBER CUSHION FOR V SERIES & VS-8/9 SERIES (1PC)		
④ SP-323	HANDLE SCREW & NUT FOR V & VS SERIES (2PCS EACH)		
⑤ SP-396	COUNTER BLADE GRIP FOR VS-8Z/VS-8R		
⑥ SP-402	COUNTER BLADE GRIP FOR VS-9R/VS-9Z		
⑦ SP-401	CUTTING BLADE GRIP FOR VS-8Z		
⑧ SP-404	CUTTING BLADE GRIP FOR VS-9Z		
⑨ SP-415	COUNTER BLADE GRIP FOR VS-7Z/VS-7R		
⑩ SP-417	CUTTING BLADE GRIP FOR VS-7Z		
⑪ SP-432	RUBBER CUSHION FOR VS-7R/7Z AND CB-8/9 (RED, 1 PC)		

160-0.35 / 160-0.6 / 160-1.2 / 160-1.8 / 160-2.4 / 180-1.2 / 180-1.8 / 180-2.4

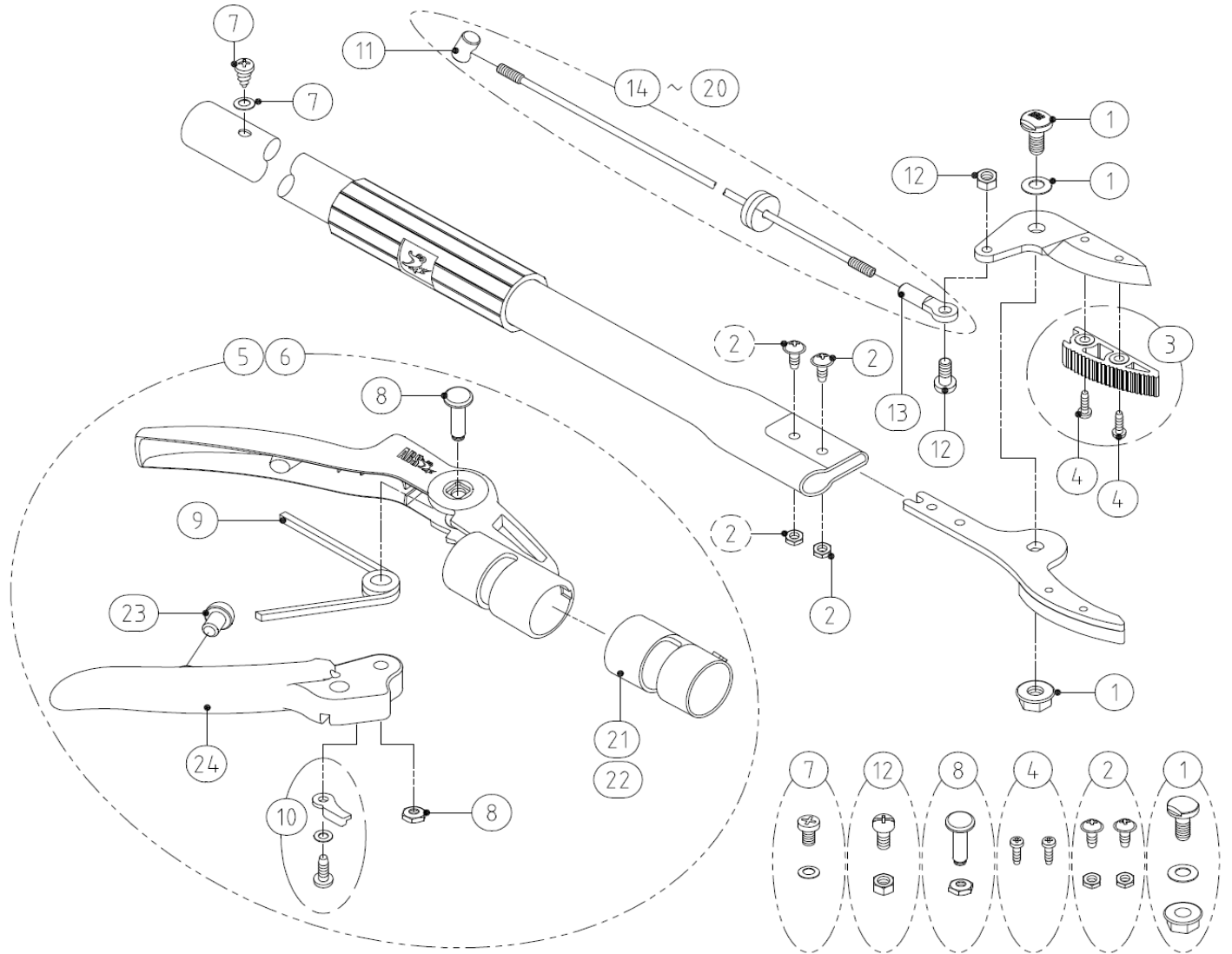

PARTS NO.	SPECIFICATION	PARTS NO.	SPECIFICATION
① SP-30	BOLT,WASHER & NUT FOR 160/180 SERIES	⑪ SP-43	ROD FIXING PART FOR LONG REACH PRUNER
② SP-31	SCREW & NUT FOR 160/180 SERIES (2PCS EACH)	⑫ SP-44	ROD FIXING BOLT & NUT FOR 150/160/180/ 190 SERIES
③ SP-32	HOLDING DEVICE OF THE CUTTING BLADE WITH 2 SCREWS FOR 160 SERIES	⑬ SP-45	ROD CAP FOR LONG REACH PRUNER
④ SP-33	SCREW FOR 160 SERIES (2PCS)	⑭ SP-46	ROD SET FOR 160/180-1.8
⑤ SP-38-A	HANDLE SET FOR LONG REACH PRUNER, FOR 160-0.35/0.6/1.2/1.8	⑮ SP-48	ROD SET FOR 160/180-2.4
⑥ SP-38-B	HANDLE SET FOR LONG REACH PRUNER, FOR 160-1.8/2.4 & 180 SERIES	⑯ SP-81	ROD SET FOR 160-0.35
⑦ SP-39	STOP SCREW AND WASHER FOR THE HANDLE OF 160/180 SERIES	⑰ SP-82	ROD SET FOR 160-0.6
⑧ SP-40	SCREW & NUT FOR THE HANDLE OF LONG REACH PRUNER	⑱ SP-83	ROD SET FOR 160/180-1.2
⑨ SP-41	SPRING FOR LONG REACH PRUNER (INC ZR SERIES,150-0.6) (1 PC)	⑲ SP-84	ROD SET FOR 160/180-2.1
⑩ SP-42	LATCH LOCK SET OF THE HANDLE FOR LONG REACH PRUNER	⑳ SP-153	ROD SET FOR 160-1.5
		㉑ SP-169	SLEEVE FOR THE GRIP OF 160-0.35/0.6/ 1.2/1.8 SERIES
		㉒ SP-168	SLEEVE FOR THE GRIP OF 160-2.1/2.4/ 180/190 SERIES
		㉓ SP-80	RUBBER CUSHION FOR THE HANDLE OF LONG REACH PRUNER
		㉔ SP-145	GRIP LEVER ONLY FOR 160/180/180L SERIES

150-0.6

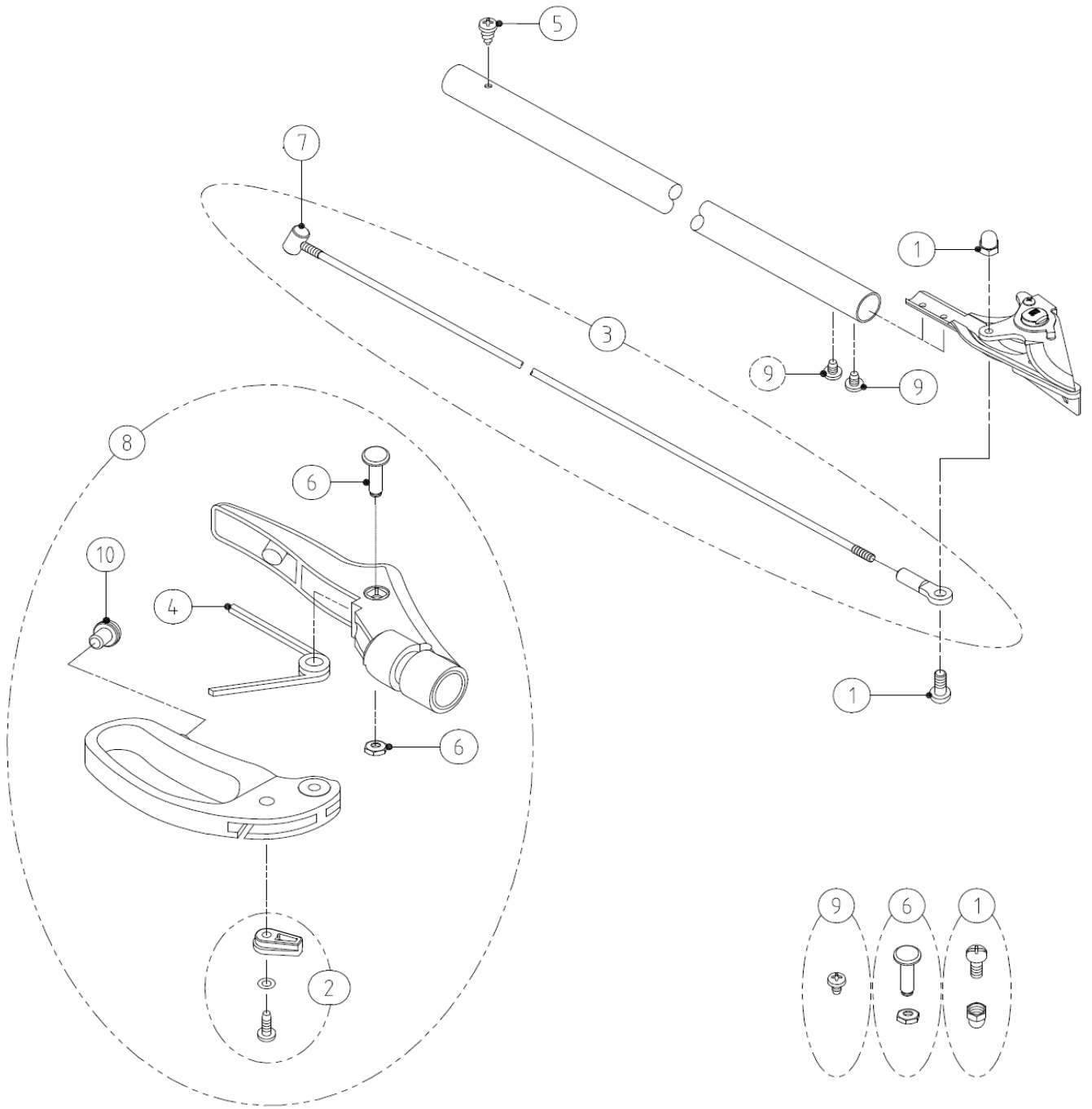

PARTS NO.	SPECIFICATION	PARTS NO.	SPECIFICATION
① SP-44	ROD FIXING BOLT & NUT FOR 150/160/ 180/190 SERIES	⑩ SP-80	RUBBER CUSHION FOR THE HANDLE OF LONG REACH PRUNER
② SP-175	LATCH LOCK SET FOR THE HANDLE OF 150-0.6		
③ SP-125	ROD SET FOR 150-0.6		
④ SP-41	SPRING FOR LONG REACH PRUNER (INC ZR SERIES,150-0.6) (1 PC)		
⑤ SP-381	STOP SCREW FOR ZR SERIES & 150-0.6		
⑥ SP-40	SCREW & NUT FOR THE HANDLE OF LONG REACH PRUNER		
⑦ SP-43	ROD FIXING PART FOR LONG REACH PRUNER		
⑧ SP-123	HANDLE SET FOR 150-0.6		
⑨ SP-174	SCREW TO ATTACH CUTTING HEAD FOR 150-0.6 (1PC)		

160ZR-2.0-3 / 160ZR-3.0-5 / 180ZR-2.0-3 / 180ZR-3.0-5

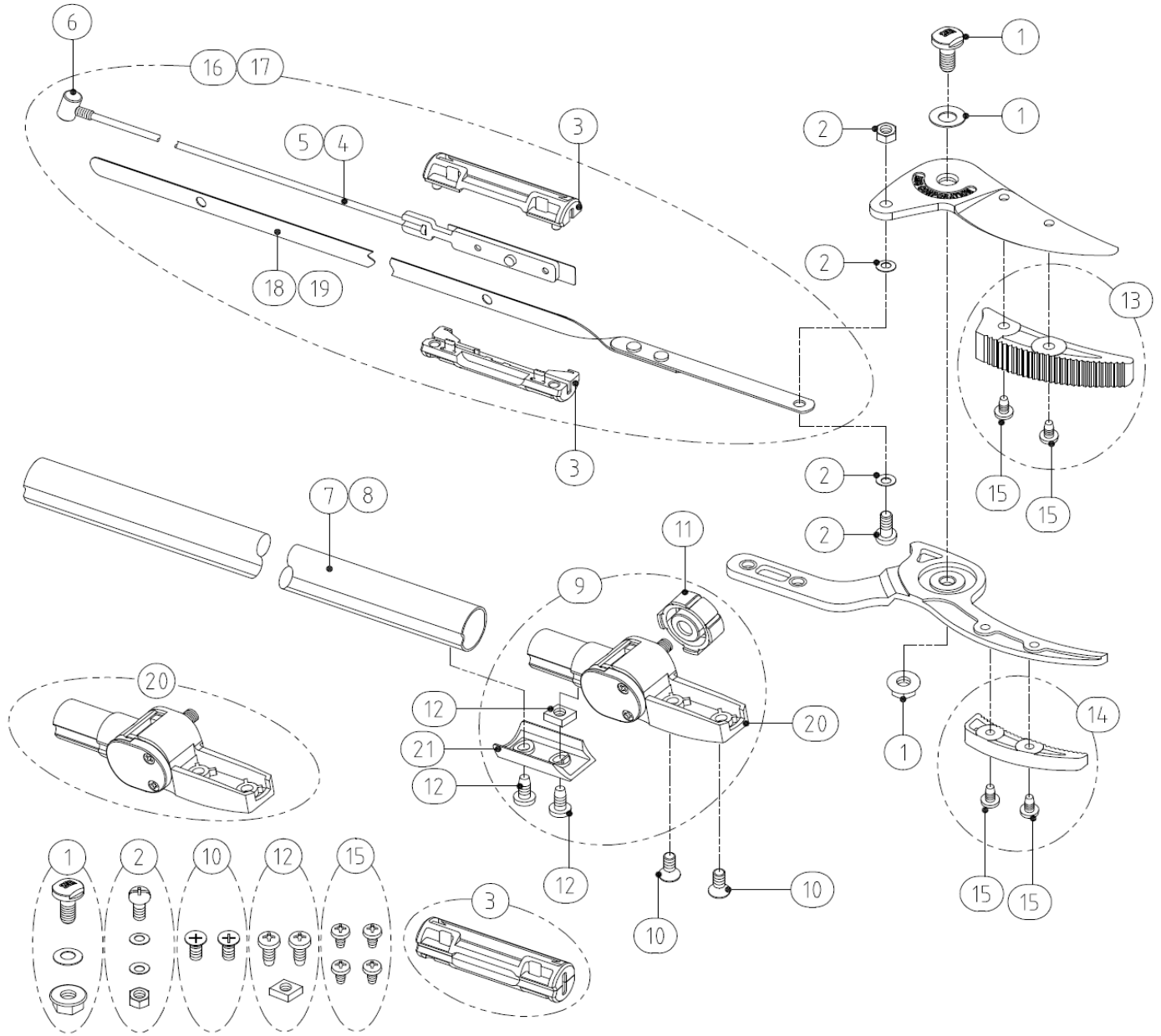

PARTS NO.	SPECIFICATION	PARTS NO.	SPECIFICATION
① SP-334	BOLT,WASHER & NUT FOR 160/180ZR SERIES	⑭ SP-352	HOLDING DEVICE FOR THE COUNTER BLADE WITH 2 SCREW FOR 160ZR
② SP-74	SCREW,NUT & 2 WASHERS FOR THE HOOP OF ZR SERIES/160R-1.8/180R-1.8	⑮ SP-353	SCREWS FOR HOLDING DEVICE OF 160ZR/160R-1.8 (4PCS)
③ SP-335	INNER CASE FOR ZR SERIES	⑯ HP-ZR-2.0-3	STEEL BAND SET FOR ZR-2.0-3
④ SP-336	ROD ONLY FOR 160/180ZR-2.0-3	⑰ HP-ZR-3.0-5	STEEL BAND SET FOR ZR-3.0-5
⑤ SP-337	ROD ONLY FOR 160/180ZR-3.0-5	⑱ SP-409	STEEL BAND ONLY FOR 160/180ZR-2.0-3
⑥ SP-338	ROD FIXING PART FOR ZR/160R/180R SERIES	⑲ SP-410	STEEL BAND ONLY FOR 160/180ZR-3.0-5
⑦ SP-340	UPPER PIPE FOR 160/180ZR-2.0-3	⑳ SP-433	TILT CASE ONLY, FOR ZR SERIES
⑧ SP-341	UPPER PIPE FOR 160/180ZR-3.0-5	㉑ SP-434	TILT CASE FIXING PLATE FOR ZR SERIES (W/O SCREWS)
⑨ SP-344	TILT CASE SET FOR 160/180ZR		
⑩ SP-345	SCREW TO ATTACHE THE CUTTING HEAD FOR ZR SERIES (2PCS)		
⑪ SP-346	DIAL NUT FOR 160/180ZR		
⑫ SP-347	2 SCREWS & 1 NUT FOR ZR SERIES		
⑬ SP-351	HOLDING DEVICE FOR THE CUTTING BLADE WITH 2 SCREW FOR 160ZR		

160ZR-2.0-3 / 160ZR-3.0-5 / 180ZR-2.0-3 / 180ZR-3.0-5

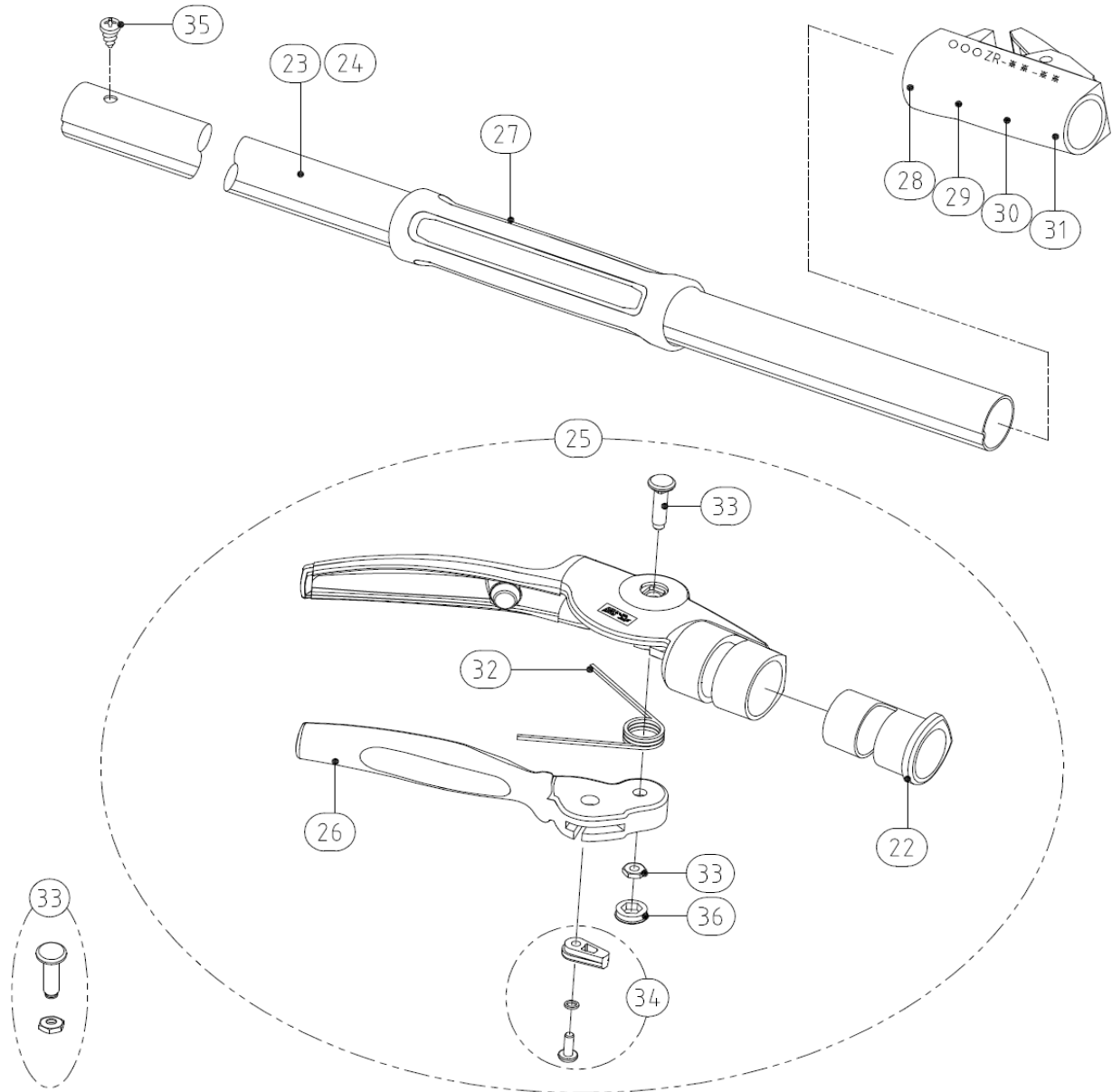

PARTS NO.	SPECIFICATION	PARTS NO.	SPECIFICATION
② SP-339	SLEEVE FOR THE GRIP OF ZR/160R/180R SERIES	③⑥ SP-414	NUT CAP FOR THE HANDLE OF ZR/160R/180R SERIES
②③ SP-342	LOWER PIPE ONLY, FOR 160/180ZR-2.0-3		
②④ SP-343	LOWER PIPE ONLY, FOR 160/180ZR-3.0-5		
②⑤ SP-348	GRIP SET FOR 160/180ZR		
②⑥ SP-349	GRIP LEVER ONLY FOR ZR/160R/180R SERIES		
②⑦ SP-350	MIDDLE GRIP FOR ZR/160R/180R		
②⑧ SP-354	JOINT CASE SET FOR 160ZR-2.0-3		
②⑨ SP-355	JOINT CASE SET FOR 160ZR-3.0-5		
③⑩ SP-356	JOINT CASE SET FOR 180ZR-2.0-3		
③① SP-357	JOINT CASE SET FOR 180ZR-3.0-5		
③② SP-41	SPRING FOR LONG REACH PRUNER (INC ZR SERIES,150-0.6) (1 PC)		
③③ SP-379	CENTER BOLT & NUT FOR GRIP OF ZR SERIES		
③④ SP-380	HANDLE LATCH LOCK SET FOR ZR/160R/ 180R SERIES		
③⑤ SP-381	STOP SCREW FOR ZR SERIES & 150-0.6		

160R-1.8 / 180R-1.8

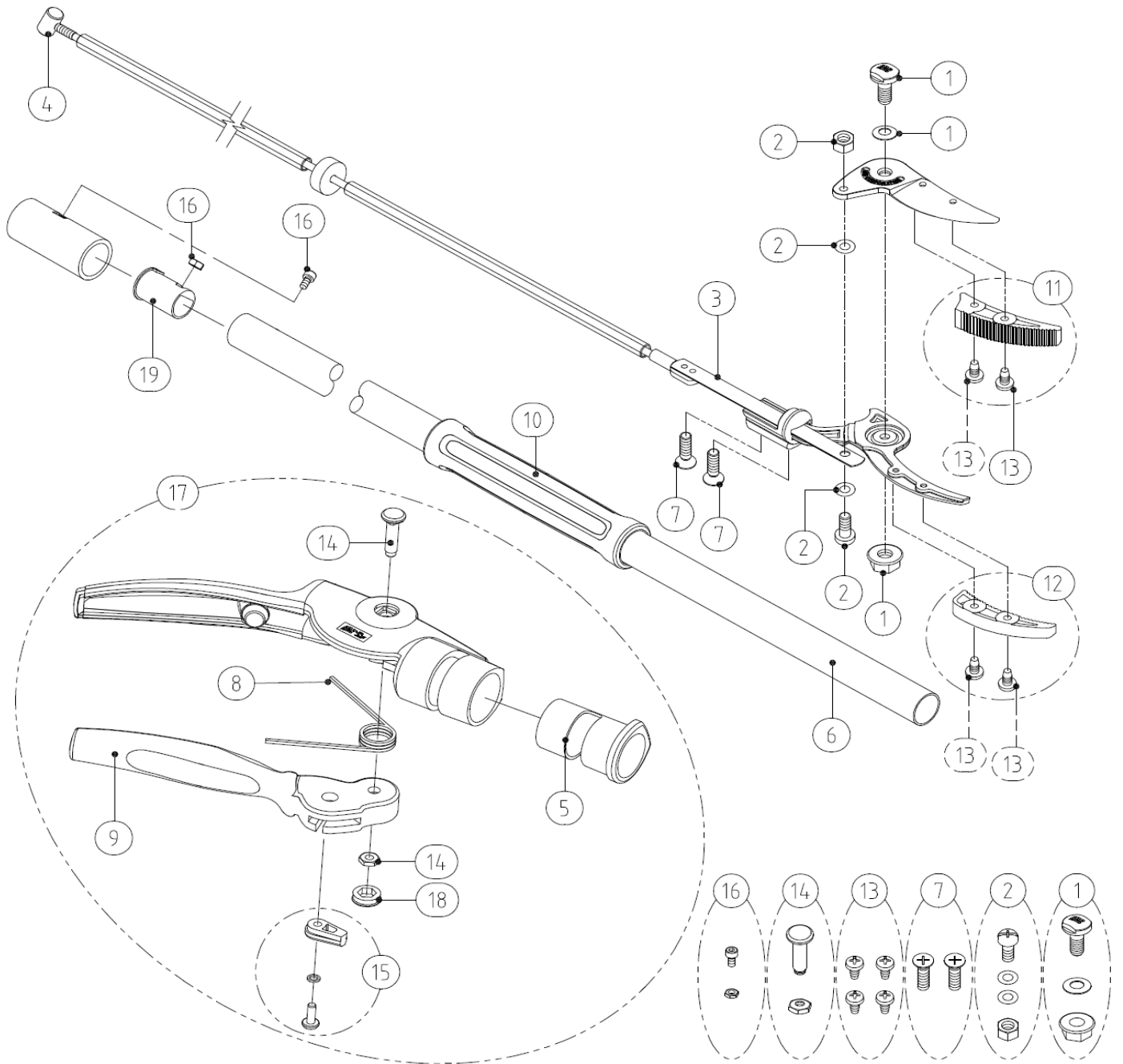

PARTS NO.	SPECIFICATION	PARTS NO.	SPECIFICATION
① SP-334	BOLT,WASHER & NUT FOR 160/180ZR SERIES	⑫ SP-352	HOLDING DEVICE FOR THE COUNTER BLADE WITH 2 SCREW FOR 160ZR
② SP-74	SCREW,NUT & 2 WASHERS FOR THE HOOP OF ZR SERIES/160R-1.8/180R-1.8	⑬ SP-353	SCREWS FOR HOLDING DEVICE OF 160ZR/160R-1.8 (4PCS)
③ SP-392	ROD FOR 160R/180R-1.8	⑭ SP-379	CENTER BOLT & NUT FOR GRIP OF ZR SERIES
④ SP-338	ROD FIXING PART FOR ZR/160R/180R SERIES	⑮ SP-380	HANDLE LATCH LOCK SET FOR ZR/160R/180R SERIES
⑤ SP-339	SLEEVE FOR THE GRIP OF ZR/160R/180R SERIES	⑯ SP-400	STOP SCREW & NUT FOR 160R/180R
⑥ SP-393	PIPE FOR 160R/180R-1.8	⑰ SP-348	GRIP SET FOR 160/180ZR
⑦ SP-399	SCREW TO ATTACHED CUTTING BLADE FOR 160R/180R (2PCS)	⑱ SP-414	NUT CAP FOR THE HANDLE OF ZR/160R/180R SERIES
⑧ SP-41	SPRING FOR LONG REACH PRUNER (INC ZR SERIES,150-0.6) (1 PC)	⑲ SP-418	SLEEVE FOR STOP SCREW & NUT OF 160R/180R-1.8
⑨ SP-349	GRIP LEVER ONLY FOR ZR/160R/180R SERIES		
⑩ SP-350	MIDDLE GRIP FOR ZR/160R/180R		
⑪ SP-351	HOLDING DEVICE FOR THE CUTTING BLADE WITH 2 SCREW FOR 160ZR		

180LR-1.2/1.8/2.1

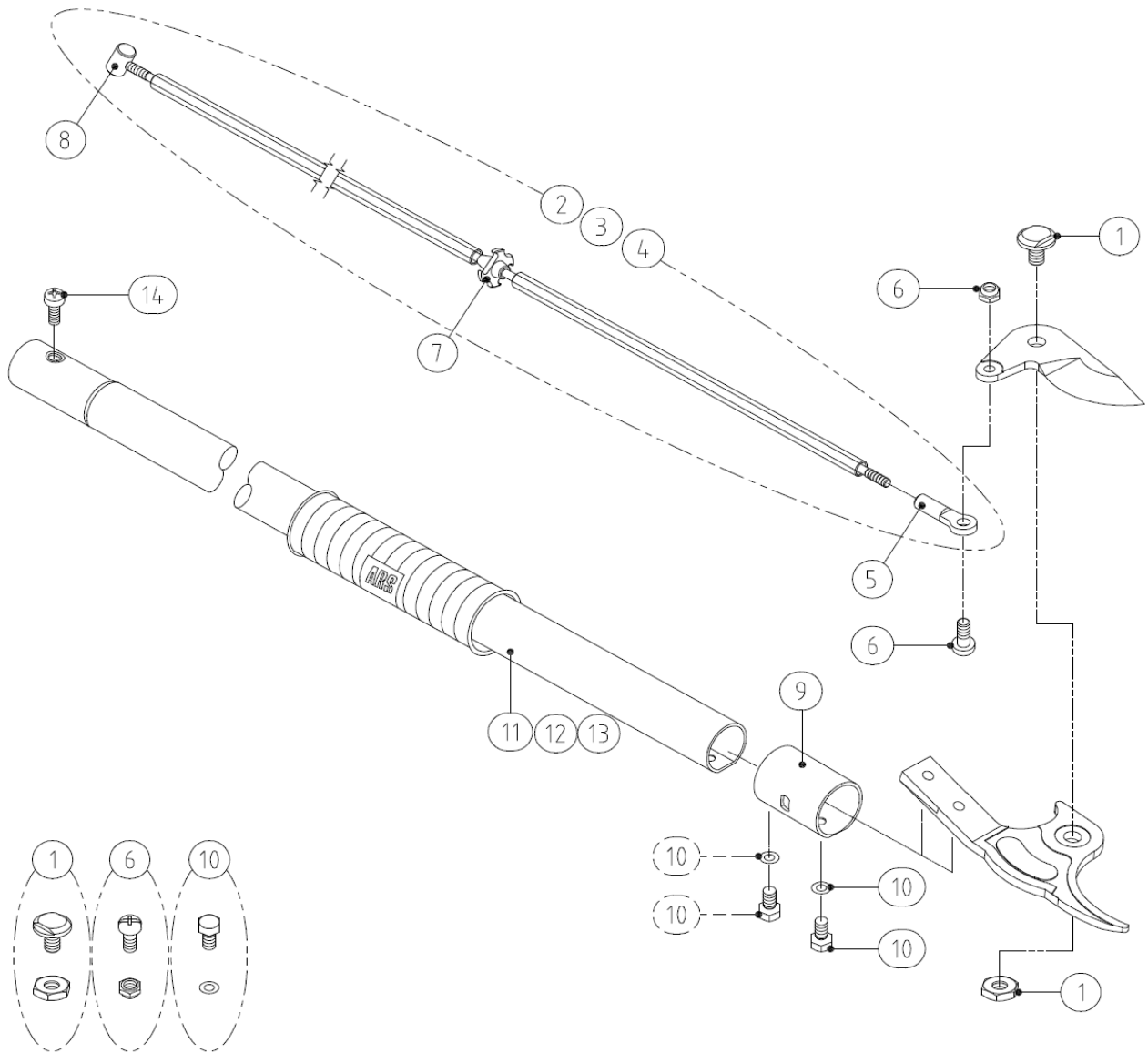

PARTS NO.	SPECIFICATION	PARTS NO.	SPECIFICATION
①	SP-216 BOLT & NUT FOR 180L/LR SERIES		
②	SP-446 ROD SET FOR 180LR-1.2		
③	SP-447 ROD SET FOR 180LR-1.8		
④	SP-448 ROD SET FOR 180LR-2.1		
⑤	SP-264 ROD CAP FOR 180L/LR SERIES		
⑥	SP-259 ROD FIXING BOLT & NUT FOR 180L/LR SERIES		
⑦	SP-235 ROD HOLDING DISK FOR 180L/LR SERIES		
⑧	SP-338 ROD FIXING PART FOR ZR/160R/180R/ 180LR SERIES		
⑨	SP-435 BLADE FIXING COLLAR FOR 180L/LR SERIES		
⑩	SP-239 BLADE HOLDING BOLT & WASHER FOR 180L/ LR SERIES (1 PC EACH)		
⑪	SP-449 PIPE FOR 180LR-1.2 WITH MIDDLE GRIP		
⑫	SP-450 PIPE FOR 180LR-1.8 WITH MIDDLE GRIP		
⑬	SP-451 PIPE FOR 180LR-2.1 WITH MIDDLE GRIP		
⑭	SP-452 STOP SCREW FOR THE HANDLE OF 180LR SERIES		

180LR-1.2/1.8/2.1

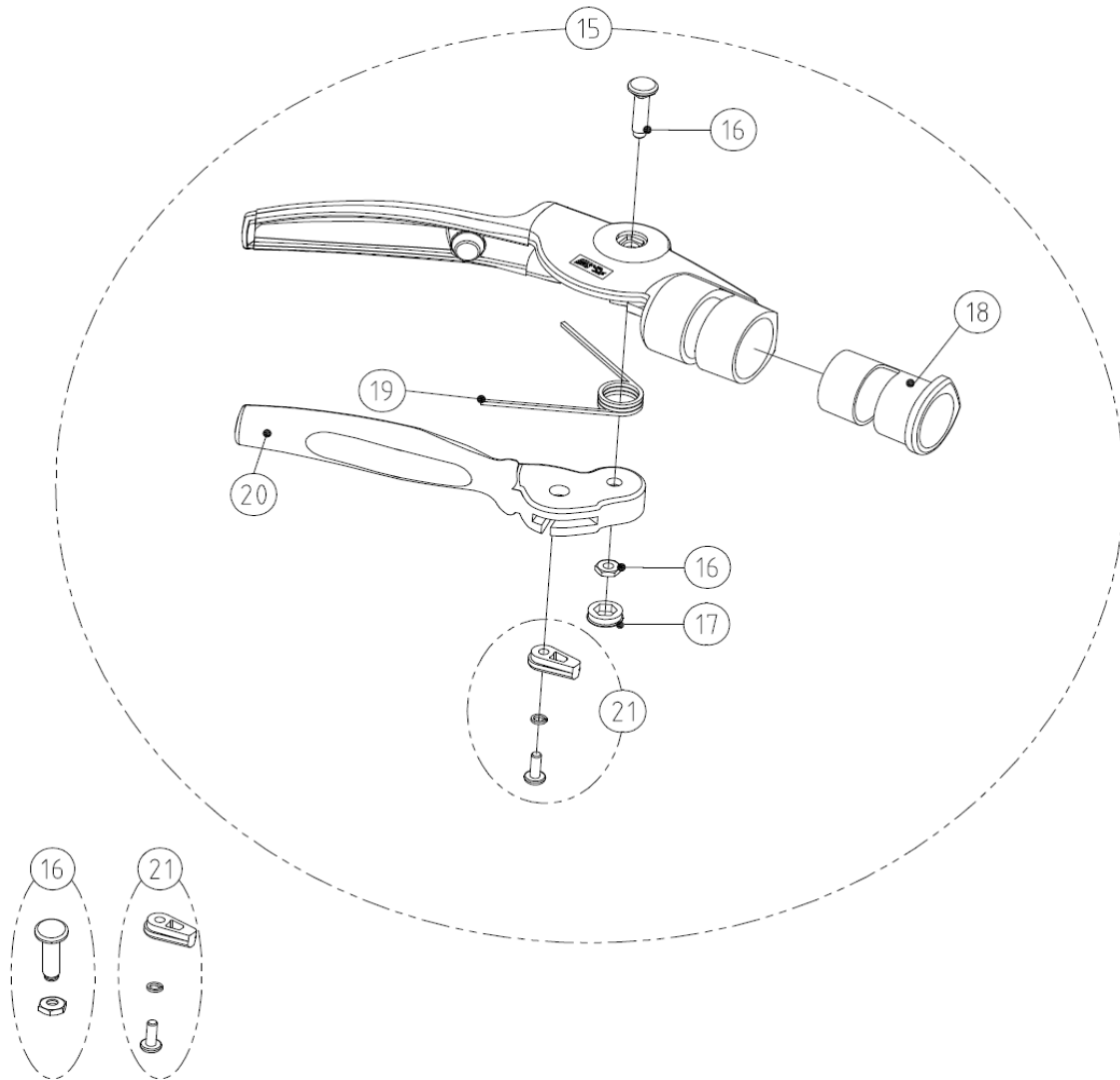

PARTS NO.	SPECIFICATION	PARTS NO.	SPECIFICATION
⑮ SP-348	GRIP SET FOR ZR/160R/180R/180LR SERIES		
⑯ SP-379	CENTER BOLT & NUT FOR GRIP OF ZR/160R/ 180R/180LR SERIES		
⑰ SP-414	NUT CAP FOR THE HANDLE OF ZR/160R/ 180R/180LR SERIES		
⑱ SP-339	SLEEVE FOR THE GRIP OF ZR/160R/180R/ 180LR SERIES		
⑲ SP-41	SPRING FOR LONG REACH PRUNER (INC ZR SERIES,150-0.6) (1 PC)		
⑳ SP-349	GRIP LEVER ONLY FOR ZR/160R/180R/ 180LR SERIES		
㉑ SP-380	HANDLE LATCH LOCK SET FOR ZR/160R/180R/ 180LR SERIES		

185-1.2 / 185-1.5 / 185-1.8

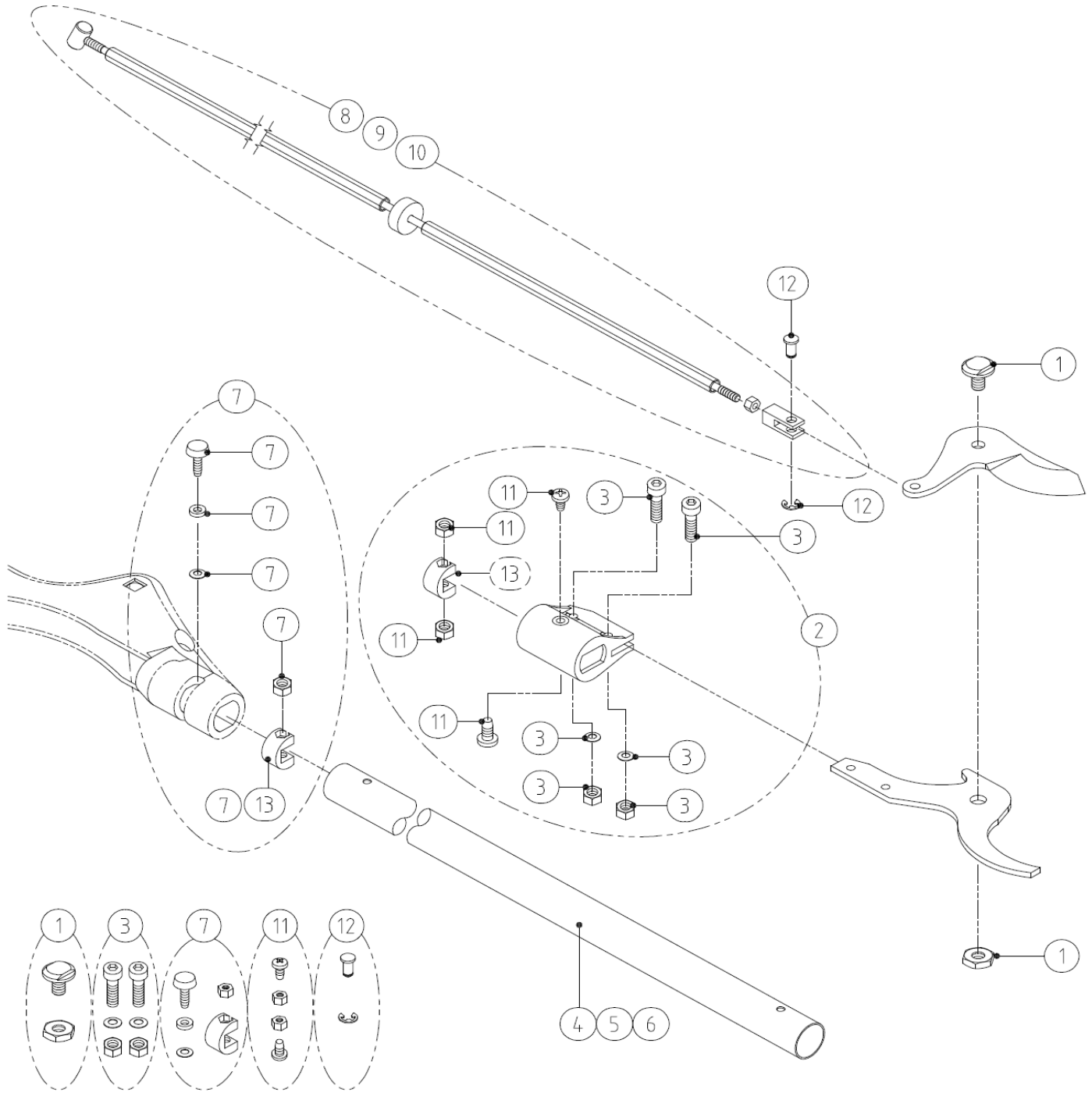

PARTS NO.	SPECIFICATION	PARTS NO.	SPECIFICATION
① SP-205	BOLT & NUT FOR 185-1.2/185-1.5/185-1.8	⑪ SP-240	BOLT & NUT FOR FITTING PARTS SET FOR 185 SERIES (2PCS EACH)
② SP-206	FITTING PARTS SET FOR 185-1.2/185-1.5/ 185-1.8	⑫ SP-163	ROD FIXING PIN & STOPPER FOR 185 SERIES
③ SP-207	CAP BOLT, NUT & WASHER FOR 185-1.2/ 185-1.5/185-1.8 (2PCS EACH)	⑬ SP-412	ROD GUIDE FOR 185 SERIES (1PC)
④ SP-208	PIPE FOR 185-1.2		
⑤ SP-209	PIPE FOR 185-1.5		
⑥ SP-210	PIPE FOR 185-1.8		
⑦ SP-213	BOLT, NUT, TUBE, WASHER & ROD GUIDE FOR 185 SERIES		
⑧ SP-230	ROD SET FOR 185-1.2		
⑨ SP-231	ROD SET FOR 185-1.5		
⑩ SP-232	ROD SET FOR 185-1.8		

185-1.2 / 185-1.5 / 185-1.8

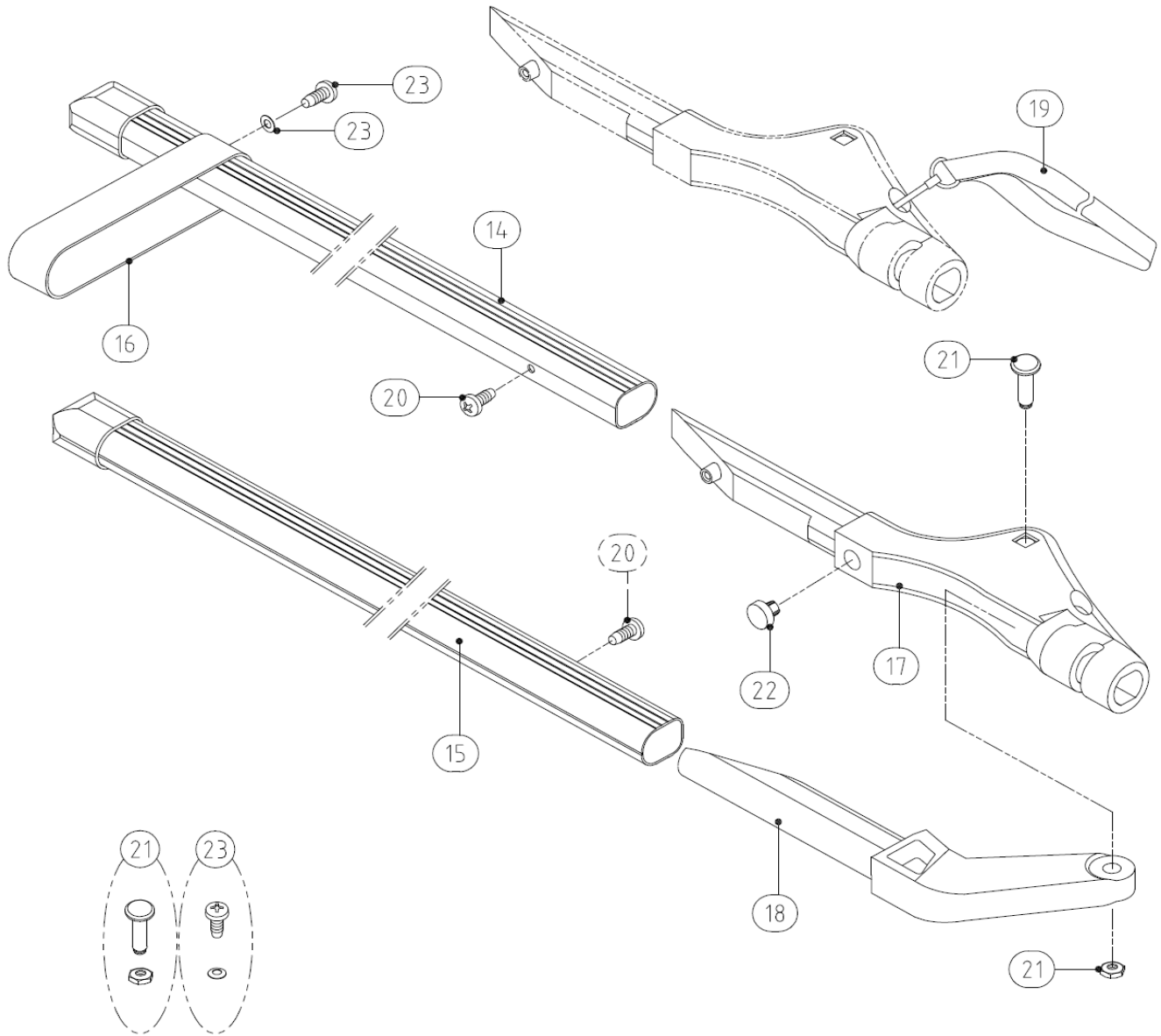

PARTS NO.	SPECIFICATION	PARTS NO.	SPECIFICATION
⑭ SP-211	LEVER PIPE 1 WITH END CAP FOR 185-1.2/ 185-1.5/185-1.8		
⑮ SP-212	LEVER PIPE 2 WITH END CAP FOR 185-1.2/ 185-1.5/185-1.8		
⑯ SP-214	STOPPER BAND ONLY, FOR 185-1.2/185-1.5/ 185-1.8		
⑰ SP-252	GRIP ONLY FOR 185-1.2/185-1.5/185-1.8		
⑱ SP-253	LEVER ONLY FOR 185-1.2/185-1.5/185-1.8		
⑲ SP-254	STRAP FOR 185 SERIES		
⑳ SP-318	BOLT FOR LEVER PIPE FOR 185 SERIES (1PC)		
㉑ SP-319	BOLT & NUT FOR GRIP OF 185 SERIES		
㉒ SP-411	RUBBER CUSHION FOR THE HANDLE OF 185 SERIES		
㉓ SP-413	BOLT & NUT FOR THE STOPPER BAND OF 185 SERIES		

LPB-20S / LPB-20M / LPB-20L

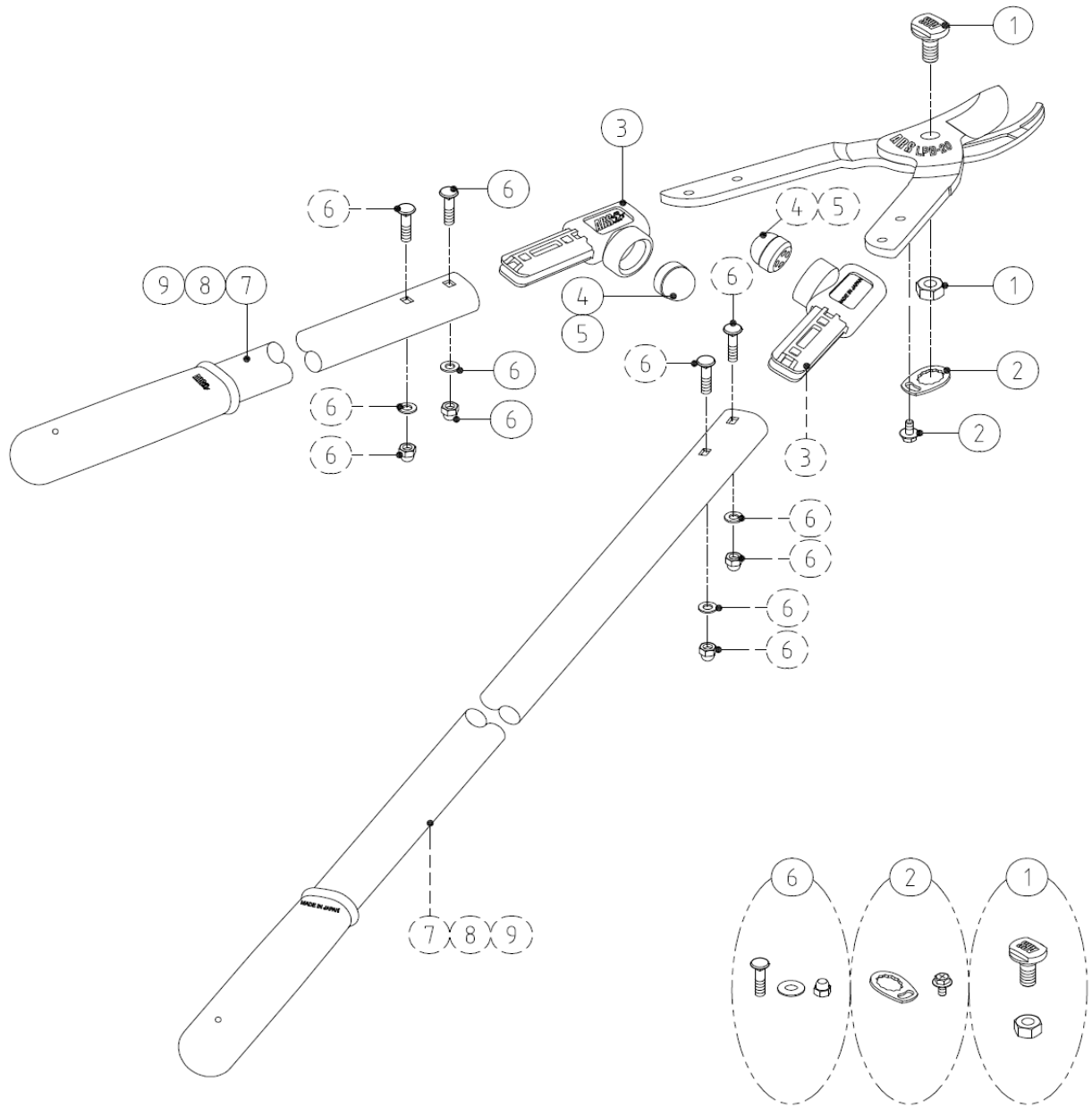

PARTS NO.	SPECIFICATION	PARTS NO.	SPECIFICATION
① SP-288	CENTRE BOLT & NUT FOR LP-22/33 AND LPB SERIES		
② SP-426	SCREW RETAINER SET FOR LPB SERIES & LPA-30L		
③ SP-419	BUMPER SOCKET FOR LPB SERIES (1PC)		
④ SP-420	SHOCK ABSORBER FOR LPB-20S/30S (1PC)		
⑤ SP-421	SHOCK ABSORBER FOR LPB-20M/L AND LPB-30M/L (1PC)		
⑥ SP-387	BLADE HOLDING BOLT,NUT & WASHER FOR LPA-30L AND LPB SERIES(/1PC)		
⑦ SP-422	PIPE WITH GRIP FOR LPB-20S/30S (1PC)		
⑧ SP-423	PIPE WITH GRIP FOR LPB-20M/30M (1PC)		
⑨ SP-389	PIPE WITH GRIP FOR LPA-30L & LPB-20L/30L (1PC)		

LPB-30S / LPB-30M / LPB-30L

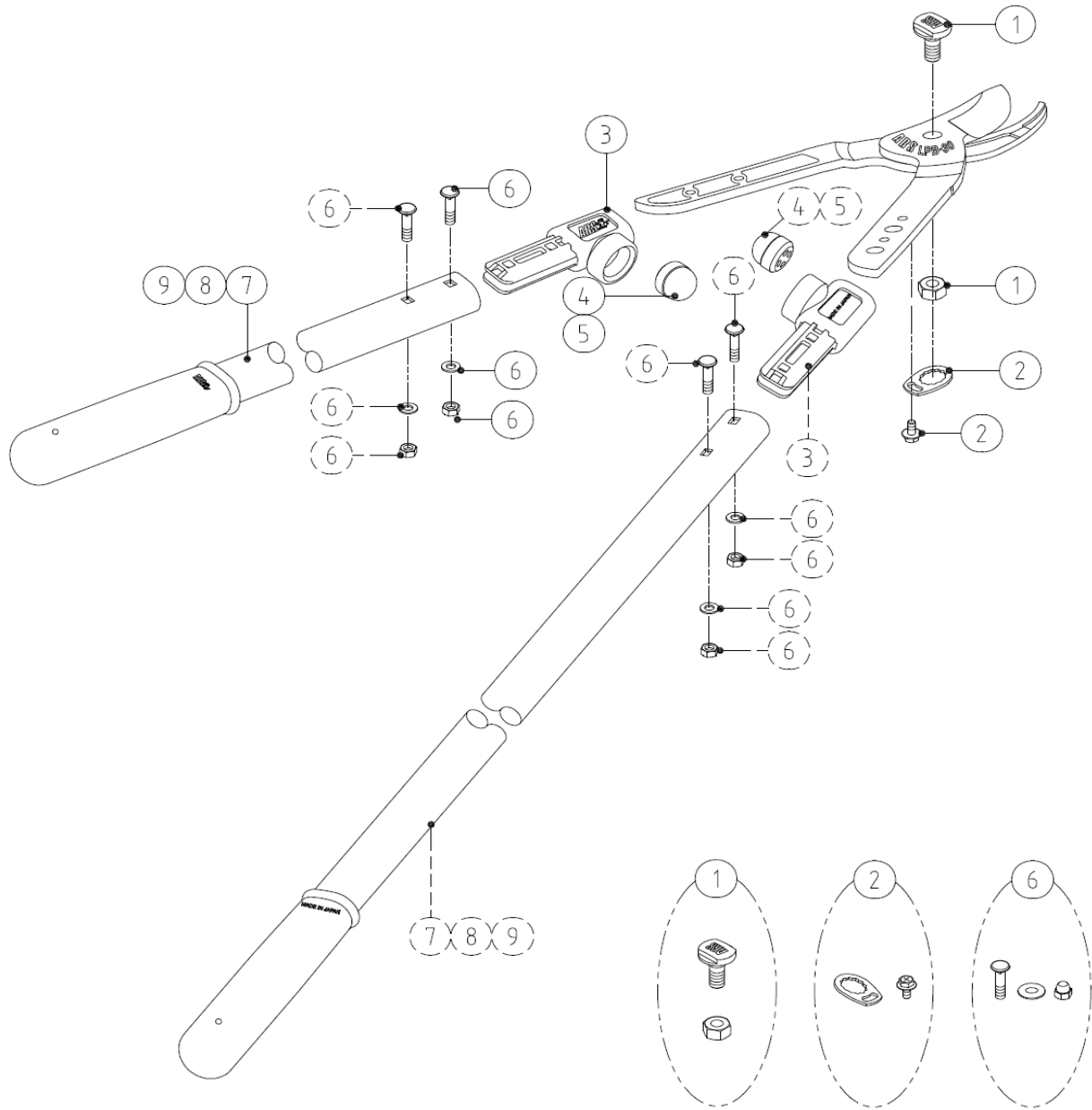

PARTS NO.	SPECIFICATION	PARTS NO.	SPECIFICATION
① SP-288	CENTRE BOLT & NUT FOR LP-22/33 AND LPB SERIES		
② SP-426	SCREW RETAINER SET FOR LPB SERIES & LPA-30L		
③ SP-419	BUMPER SOCKET FOR LPB SERIES (1PC)		
④ SP-420	SHOCK ABSORBER FOR LPB-20S/30S (1PC)		
⑤ SP-421	SHOCK ABSORBER FOR LPB-20M/L AND LPB-30M/L (1PC)		
⑥ SP-387	BLADE HOLDING BOLT,NUT & WASHER FOR LPA-30L AND LPB SERIES(/1PC)		
⑦ SP-422	PIPE WITH GRIP FOR LPB-20S/30S (1PC)		
⑧ SP-423	PIPE WITH GRIP FOR LPB-20M/30M (1PC)		
⑨ SP-389	PIPE WITH GRIP FOR LPA-30L & LPB-20L/30L (1PC)		

LPA-30L

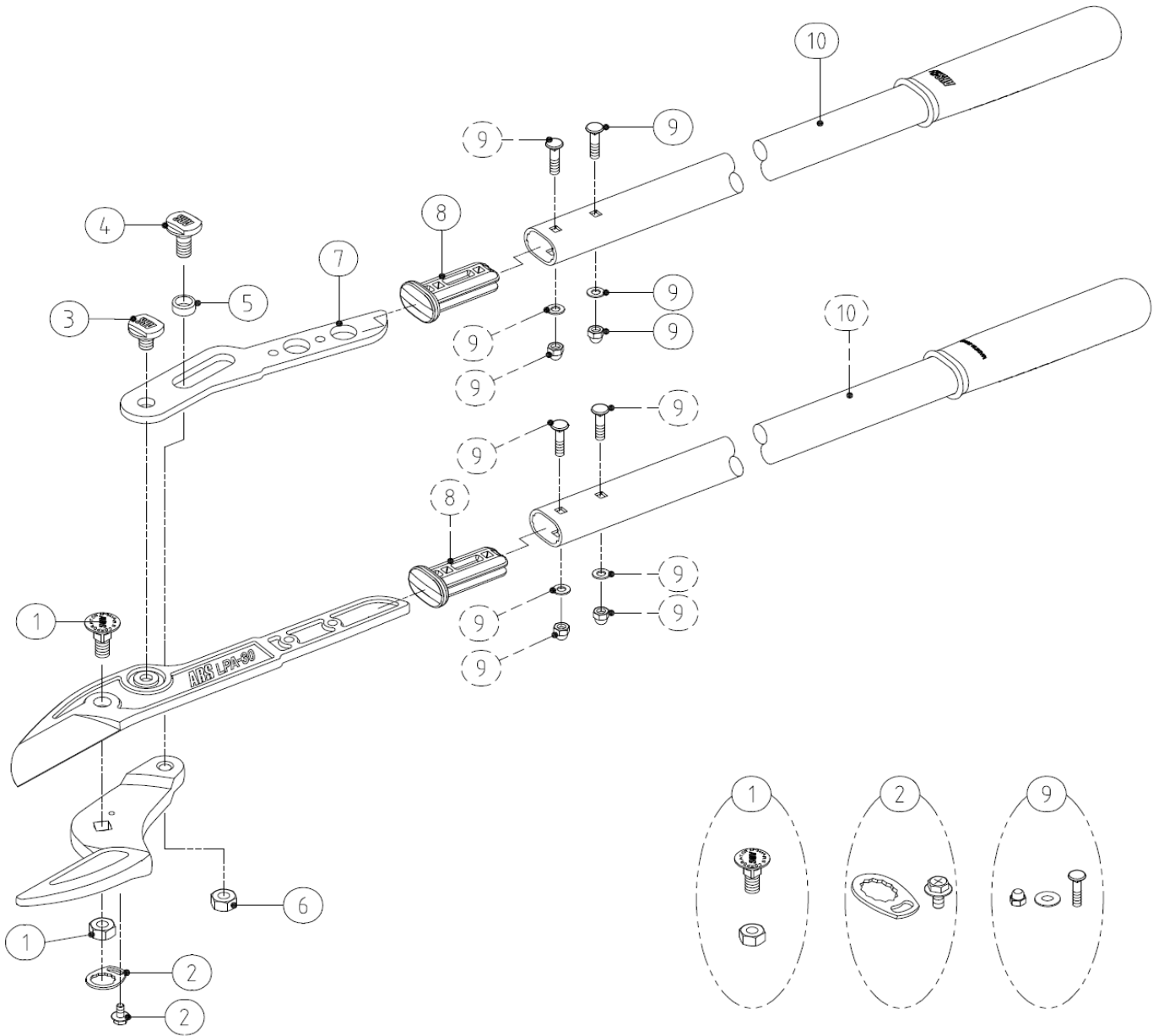

PARTS NO.	SPECIFICATION	PARTS NO.	SPECIFICATION
①	SP-278 CENTER BOLT & NUT FOR LP-40 & LPA-30L		
②	SP-426 SCREW RETAINER SET FOR LPB SERIES & LPA-30L		
③	SP-385 FULCRUM BOLT OF LINK FOR LPA-30L		
④	SP-382 FIXING BOLT FOR LINK & COUNTER BLADE OF LPA-30L		
⑤	SP-386 LINK SPACER FOR LPA-30L		
⑥	SP-383 FIXING NUT FOR LINK & COUNTER BLADE OF LPA-30L		
⑦	SP-384 LINK FOR LPA-30L		
⑧	SP-388 BLADE HOLDING SOCKET FOR LPA-30L(1PC)		
⑨	SP-387 BLADE HOLDING BOLT,NUT & WASHER FOR LPA-30L AND LPB SERIES(/ 1PC)		
⑩	SP-389 PIPE WITH GRIP FOR LPA-30L & LPB-20L/30L (1PC)		

